

XP Series

Pure Sine Wave Inverter

For All Home & Office Appliances

User's Manual

Version 1.0



**Utility + Inverter + Charger + Transfer SW + Solar Power + AGS
All in One**

XP Series Inverter/Charger

Installation and Operation Manual

Table of Contents

1. Important Safety Information.....	- 3 -
1-1. General Safety Precautions.....	- 3 -
1-2. Precautions When Working with Batteries.....	- 3 -
2. Introduction.....	- 5 -
2-1. General Information.....	- 5 -
2-2. Application.....	- 5 -
2-3 The Appearance and Mechanical Drawing of XP Series.....	- 6 -
2.3.1 The Appearance of XP Series.....	- 6 -
2.3.2 The Mechanical Drawing of XP Series.....	- 7 -
2-4 Features.....	- 11 -
2-5 Electrical Performance.....	- 11 -
2.5.1 Inverter.....	- 11 -
2.5.2 AC Charger.....	- 11 -
2.5.3 Transfer.....	- 14 -
2.5.4 Frequency adjust.....	- 14 -
2.5.5 Solar Charger.....	- 14 -
2.5.6 Automatic Voltage Regulation(Optional).....	- 15 -
2.5.7 Power Saver Mode.....	- 17 -
2.5.8 Protections.....	- 18 -
2.5.9 Remote control Module.....	- 19 -
2.5.10 LED Indicator & LCD.....	- 19 -
2.5.11 Audible Alarm.....	- 20 -
2.5.12 FAN Operation.....	- 21 -
2.5.13 DIP Switches.....	- 21 -
2.5.14 Output Socket.....	- 23 -
2.5.15 Other features.....	- 23 -
3 Installation.....	- 25 -
3-1 Location.....	- 25 -
3-2 DC Wiring recommendation.....	- 25 -
3-3 AC Wiring.....	- 27 -
3-4 Install Flange.....	- 29 -
4 Battery Information.....	- 32 -
4-1 Battery Type.....	- 32 -
4-2 Battery Capacity Rating.....	- 32 -
4.2.1 Battery Discharge Rate.....	- 32 -
4.2.2 Depth of Discharge.....	- 32 -
4.2.3 Understanding Amp-Hour Requirements.....	- 32 -
4.2.4 Battery Configurations.....	- 33 -
4.2.5 Wiring Batteries.....	- 33 -
4.2.6 Batteries Maintenance.....	- 35 -
5 Troubleshooting Guide.....	- 36 -
6 Warranty.....	- 39 -
7 Ordering Information.....	- 40 -
Appendix 1.....	- 41 -
Appendix 2.....	- 41 -

1. Important Safety Information



WARNING!

This manual contains important instructions for all XP series Inverter/Charger models that shall be followed during installation and maintenance of the inverter.

1-1. General Safety Precautions

1. Before installing and using the X series Inverter/Charger, read all instructions and cautionary markings on the X series Inverter /Charger and all appropriate sections of this guide. Be sure to read all instructions and cautionary markings for any equipment attached to this unit.
2. This unit is designed for indoor use only. Do not expose the X series Inverter/Charger to rain, snow, or spray.
3. To reduce risk of fire hazard, do not cover or obstruct the ventilation openings. Do not install the X series Inverter/Charger in a zero-clearance compartment. Overheating may result.
4. Use only attachments recommended or sold by the manufacturer. Doing otherwise may result in a risk of fire, electric shock, or injury to persons.
5. To avoid a risk of fire and electric shock, make sure that existing wiring is in good condition and that wire is not undersized. Do not operate the X series Inverter/Charger with damaged or substandard wiring.
6. Do not operate the X series Inverter/Charger if it has received a sharp blow, been dropped, or otherwise damaged in any way. If the X series Inverter/Charger is damaged, see the Warranty section.
7. Do not disassemble the X series Inverter/Charger. It contains no user-serviceable parts. See Warranty for instructions on obtaining service. Attempting to service the X series Inverter/Charger yourself may result in a risk of electrical shock or fire. Internal capacitors remain charged after all power is disconnected.
8. The X series Inverter contains more than one live circuit (batteries and AC line). Power may be present at more than one source. To reduce the risk of electrical shock, disconnect both AC and DC power from the X series Inverter/Charger before attempting any maintenance or cleaning or working on any circuits connected to the X series Inverter/Charger. Turning off controls will not reduce this risk.
9. Use insulated tools to reduce the chance of short-circuits when installing or working with the inverter, the batteries, or PV array.

1-2. Precautions When Working with Batteries

1. Make sure the area around the battery is well ventilated.
2. Never smoke or allow a spark or flame near the engine or batteries.
3. Use caution to reduce the risk of dropping a metal tool on the battery. It could spark or short circuit the battery or other electrical parts and could cause an explosion.
4. Remove all metal items, like rings, brace lets, and watches when working with lead-acid batteries. Lead-acid batteries produce a short circuit current high enough to weld metal to skin, causing a severe burn.
5. Have someone within range of your voice or close enough to come to your aid when you work near a lead-acid battery.
6. Have plenty of fresh water and soap near by in case battery acid contacts skin, clothing, or eyes.
7. Wear complete eye protection and clothing protection. Avoid touching your eyes while working near batteries.
8. If battery acid contacts skin or clothing, wash immediately with soap and water. If acid enters your eye, immediately flood it with running cold water for at least twenty minutes and get medical attention immediately.
9. If you need to remove a battery, always remove the grounded terminal from the battery first. Make sure all accessories are off so you don't cause a spark.
10. Always use identical types of batteries.

11. Never install old or untested batteries. Check each battery's date code or label to ensure age and type.
12. Batteries are temperature sensitive. For optimum performance, they should be installed in a stable temperature environment.
13. Always recycle old batteries. Contact your local recycling center for proper disposal information.

2. Introduction

2-1. General Information

Thank you for purchasing the X Series Inverter/Charger.

XP Series Pure Sine Wave Inverter is a combination of an inverter, charger, solar power and Auto-transfer switch into one complete system . It is packed with unique features and it is one of the most advanced inverter/chargers in the market today.

The inverter features an AC pass-through circuit, powering your home appliances from utility or generator power while charging the battery. When utility power fails, the battery backup system keeps your appliances powered until utility power is restored. Internal protection circuits prevent over-discharge of the batteries by shutting down the inverter when a low battery condition occurs. When utility or generator power is restored, the inverter transfers to the AC source and recharges the batteries.

Accessories allow the XP series to also serve as a central hub of a renewable energy system. Set the XP Series inverter to battery priority mode, designates the inverter-preferred UPS configuration. In this configuration, the load power is normally provided by the inverter. However, if the inverter output is interrupted, an internal transfer switch automatically transfers the load from the inverter to commercial AC power. The transfer time between inverter and line is short(6ms typical), and such transfers are normally not detected by even highly sensitive loads. Upon restoration of inverter power, the inverter will transfer back to inverter power.

On the line priority mode, when utility AC power cuts off(or falls out of acceptable range), the transfer relay is de-energized and the load is automatically transferred to the Inverter output. Once the qualified AC utility is restored, the relay is energized and the load is automatically reconnected to AC utility.

It features power factor corrected, sophisticated multi-stage charging and pure sine wave output with unprecedentedly high surge capability to meet demanding power needs of inductive loads without endangering the equipment.

XP Series Inverter is equipped with a powerful charger of up to 120Amp (depending on Model). The overload capacity is 300% of continuous output for up to 20 seconds to reliably support tools and equipment longer

Another important feature is that the inverter can be easily customized to Battery priority via a DIP switch, this helps to extract maximum power from battery in renewable energy systems. Thus, the XP Series Pure Sine Wave Inverter is suitable for Renewable energy system, Utility, RV, Marine and Emergency appliances.

To get the most out of the power inverter, it must be installed, used and maintained properly. Please read the instructions in this manual before installing and operating.

2-2. Application

Power tools—circular saws, drills, grinders, sanders, buffers, weed and hedge trimmers, air compressors.

Office equipment – computers, printers, monitors, facsimile machines, scanners.

Household items – vacuum cleaners, fans, fluorescent and incandescent lights, shavers, sewing machines.

Kitchen appliances – coffee makers, blenders, ice makers, toasters.

Industrial equipment – metal halide lamp, high – pressure sodium lamp.

Home entertainment electronics – television, VCRs, video games, stereos, musical instruments, satellite equipment.

2-3 The Appearance and Mechanical Drawing of XP Series

2.3.1 The Appearance of XP Series

2.3.1.1 The Surface Photograph of XP Series



X1KW~3KW Series

XP1KW~6KW Series

XP8KW~12KW Series

2.3.1.2 The Front Side Photograph of XP Series



2.3.1.3 The Rear Side Photograph of XP8-12KW Series



2.3.2 The Mechanical Drawing of XP Series

2.3.2.1 The Front Side Mechanical Drawing of XP1-12KW Series (Single Phase Series)

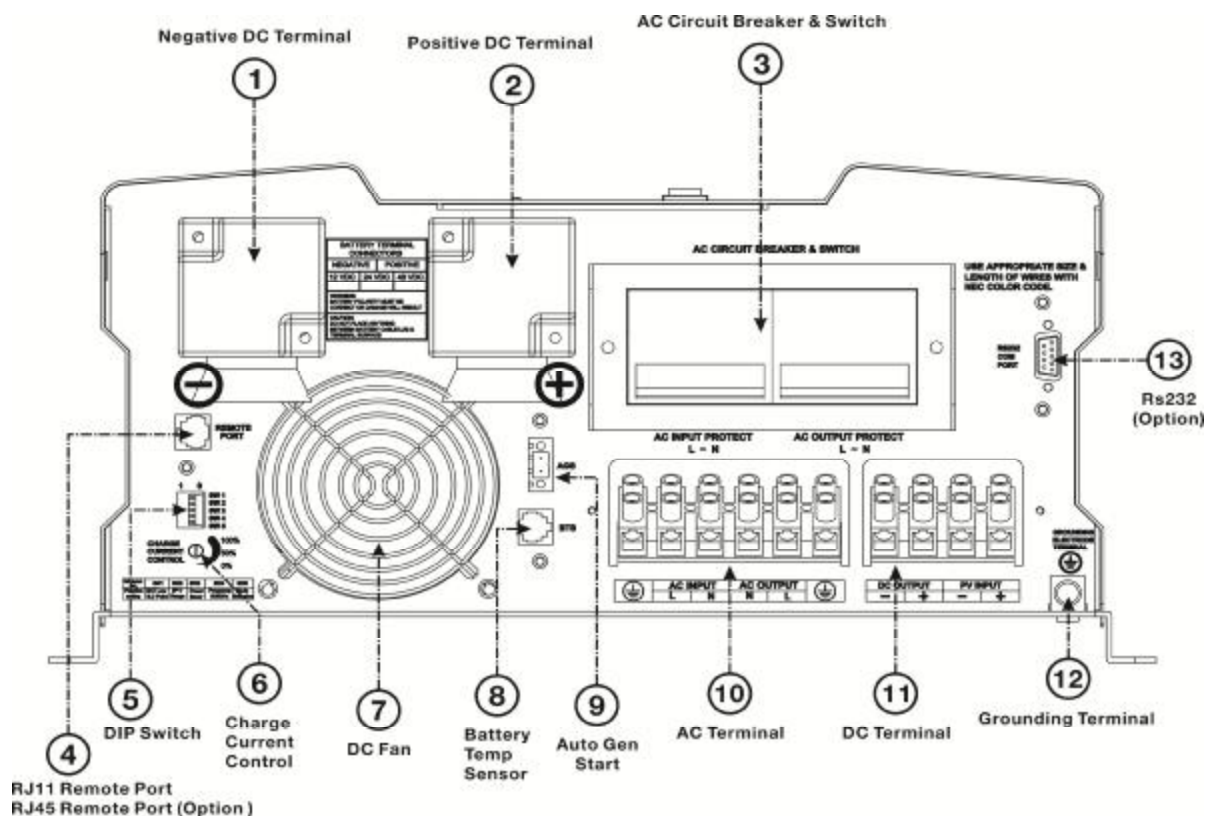

2.3.2.2 The Front Side Mechanical Drawing of XP1-12KW Series

(Daul Phase Series)

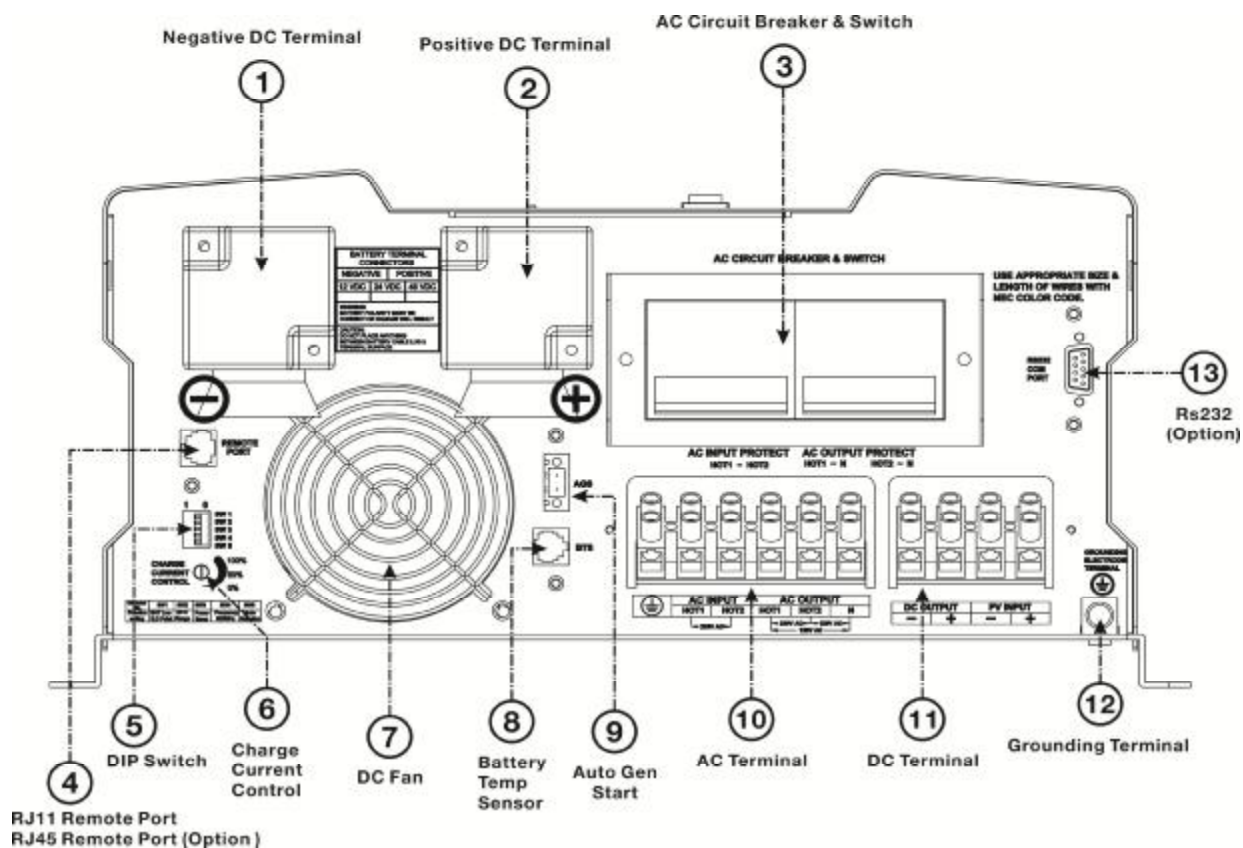

2.3.2.3 The Rear Side Mechanical Drawing of XP1-6KW Series

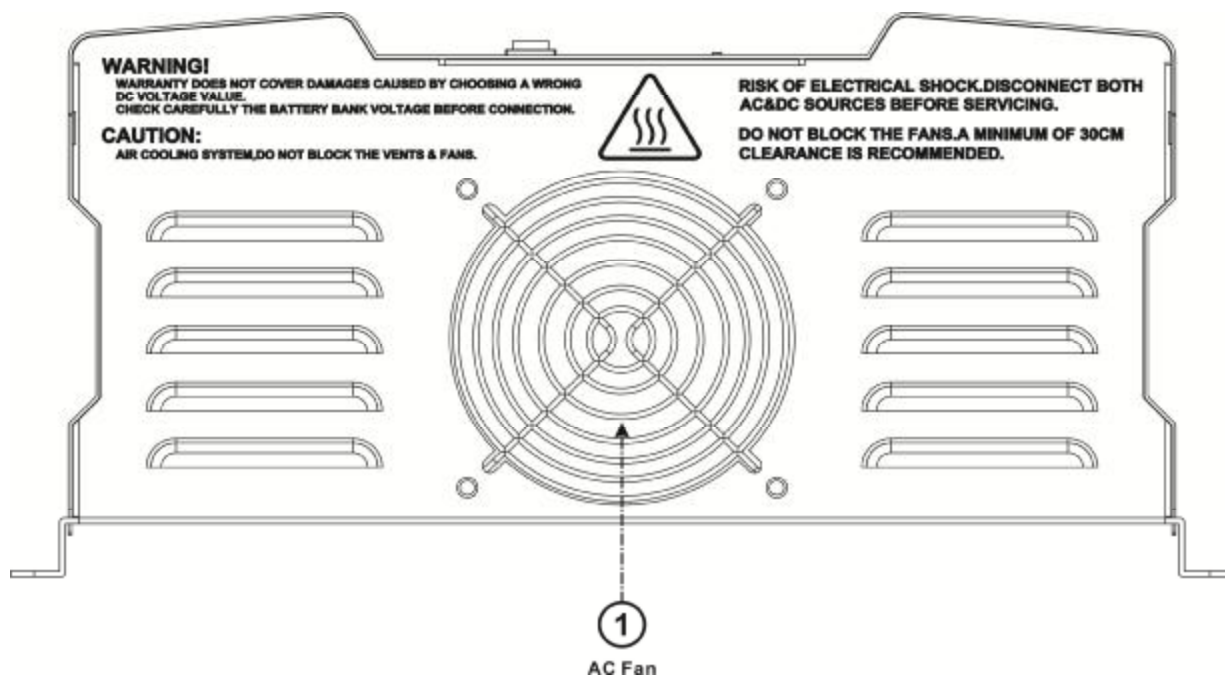

2.3.2.4 The Rear Side Mechanical Drawing of XP8-12KW Series

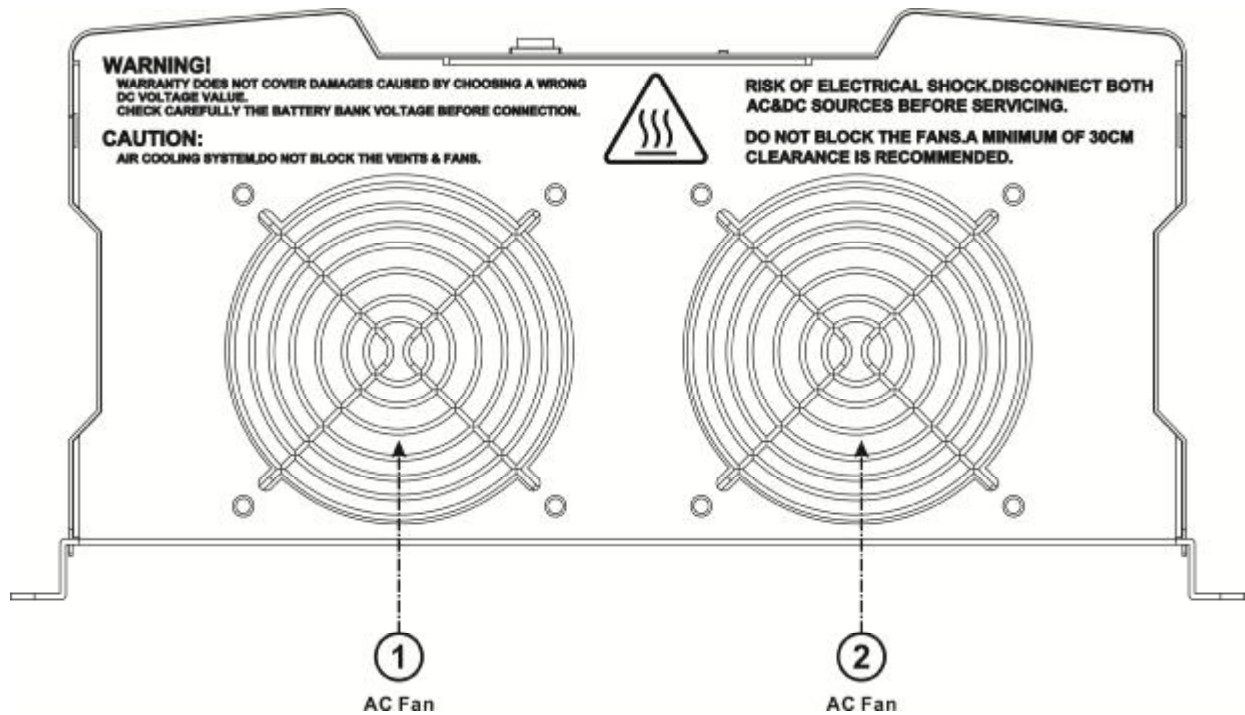

2.3.2.5 The Front Side Mechanical Drawing of X1-3KW Series

(Single Phase Series)

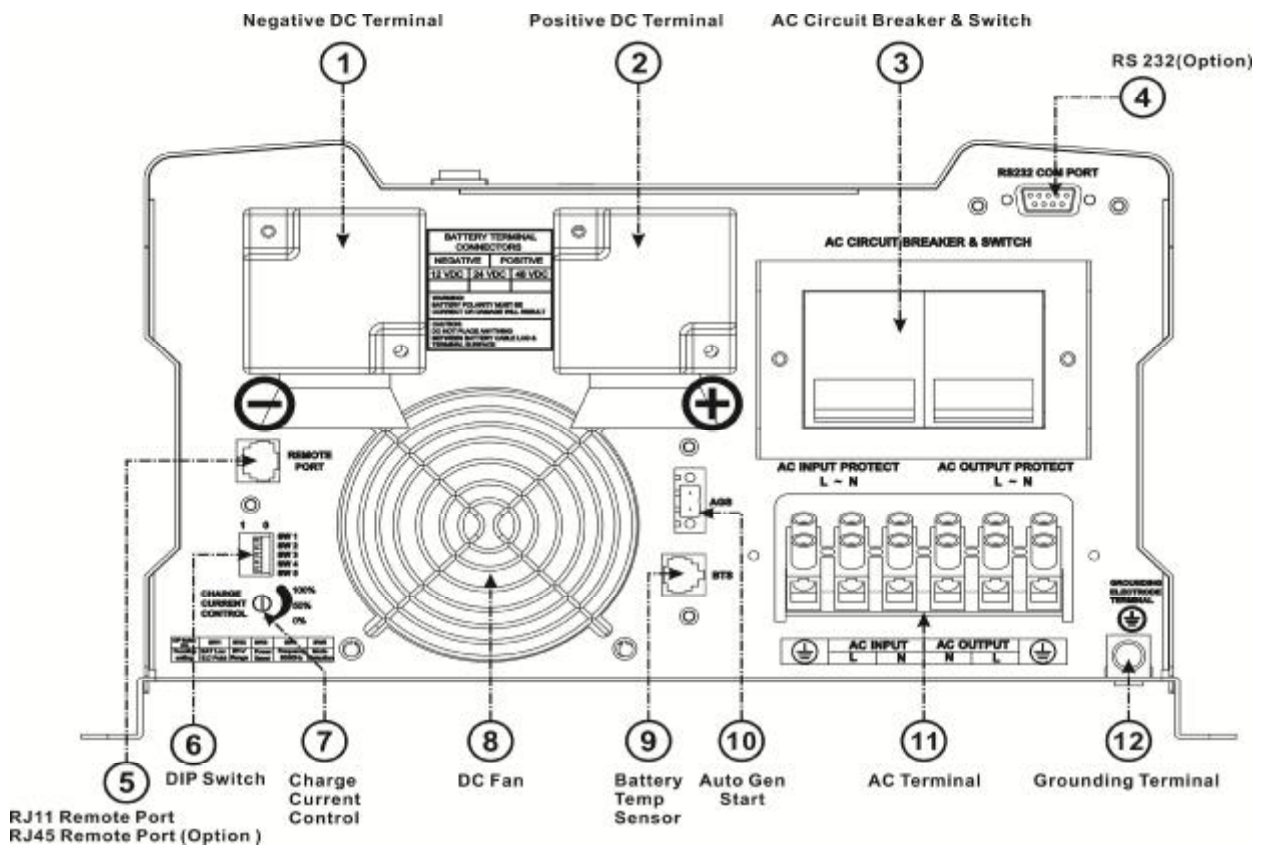

2.3.2.6 The Front Side Mechanical Drawing of X1-3KW Series

(Daul Phase Series)

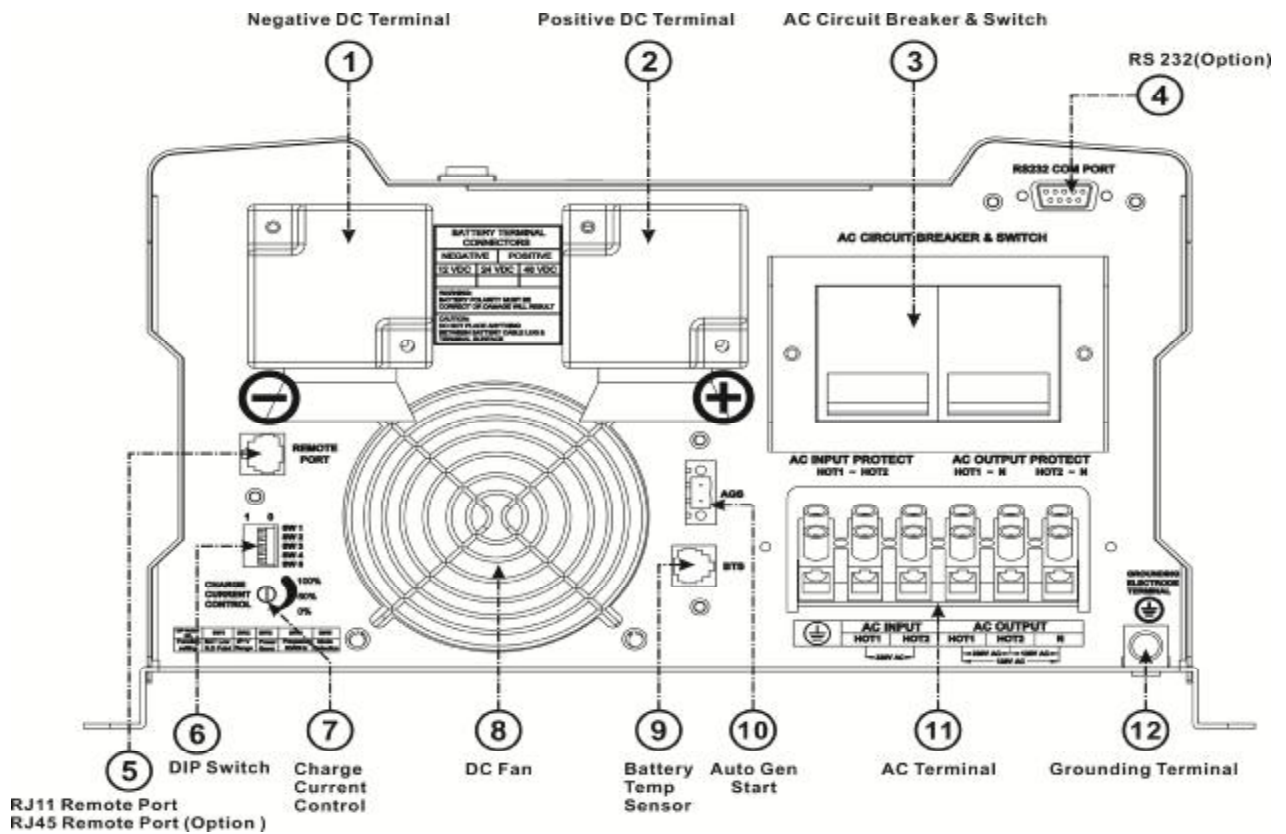

2.3.2.7 The Rear Side Mechanical Drawing of X1-3KW Series

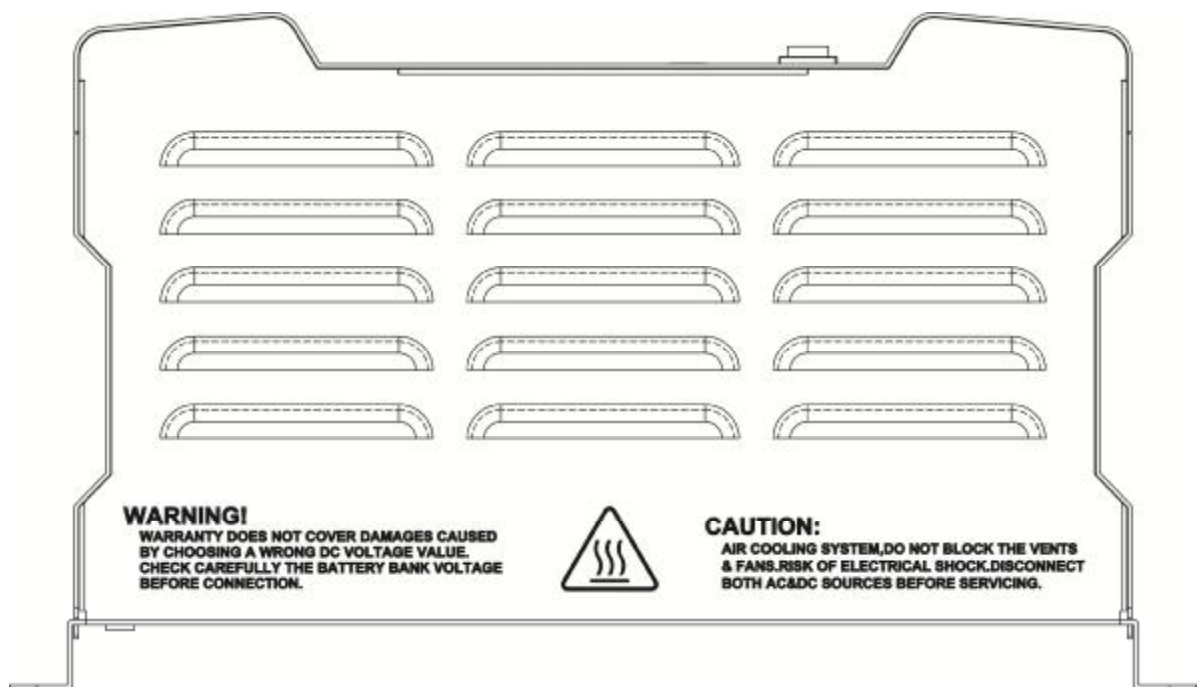

2-4 Features

- ✓ Smart Remote Control (RJ11 or RJ45)
- ✓ Battery Temperature Sensor (BTS)
- ✓ Automatic Generator Start (AGS)
- ✓ Support Solar Panel with MPPT Function
- ✓ Designed For Harsh Environment Operation
- ✓ DC Start & Automatic Self-Diagnostic Function
- ✓ Compatible With Linear & Non-Linear Load
- ✓ Easy to Install & Easy to Operate & Easy to Solve
- ✓ Low DC Voltage Supports Home & Office Appliances
- ✓ Powerful Charge Rate Up to 120Amp, Selectable From 0%-100%
- ✓ High Efficiency Design & “Power Saving Mode” to Conserve Energy
- ✓ Battery Priority Mode, Designates the Inverter-Preferred UPS Configuration
- ✓ 13 Vdc Battery Recover Point, Dedicated for Renewable Energy Systems
- ✓ 8 pre Set Battery Type Selector plus De-sulphation for Totally Flat Batteries
- ✓ 4-step Intelligent Battery Charging, PFC (Power Factor Correction) for Charger
- ✓ 8 ms Typical Transfer Time Between Utility & Battery, Guarantees Power Continuity
- ✓ 15s Delay Before Transfer when AC Recover, Protection for Load when Used with Generator

2-5 Electrical Performance

2.5.1 Inverter

Topology

The XP series inverter/charger is built according to the following topology.

Inverter: Full Bridge Topology.

AC Charger: Isolate Boost Topology

Solar Charger: MPPT PV Controller

Because of high efficiency IGBT and 16bit, 4.9MHz microprocessor and heavy transformers, it outputs PURE SINE WAVE waveform with an average THD of 8% (Max 10%) depending of load connected and battery voltage.

The peak efficiency of XP series is 88%.

Overload Capacity

The XP series inverters have different overload capacities, making it ideal to handle demanding loads.

1 For $110% < \text{Load} < 125% (\pm 10\%)$, no audible alarm in 14 minutes, beeps 0.5s every 1s in the 15th minute, and Fault(Turn off) after the 15th minute.

2 For $125% < \text{Load} < 150% (\pm 10\%)$, beeps 0.5s every 1s and Fault(Turn off) after the 1 minute.

3 For $300\% \geq \text{Load} > 150% (\pm 10\%)$, beeps 0.5s every 1s and Fault(Turn off) after 20s.

2.5.2 AC Charger

X Series is equipped with an active PFC (Power Factor Corrected) multistage battery charger. The PFC feature is used to control the amount of power used to charge the batteries in order to obtain a power factor as close as possible to 1. Unlike other inverters whose max charging current decreases according to the input AC voltage, XP series charger is able to output max current as long as input AC voltage is in the range of 164-243VAC (95-127VAC for 120V model), and AC freq is in the range of 48-54Hz(58-64Hz for 60Hz model).

The XP series inverter is with a strong charging current of 120Amp (for 4KW,12V), and the max charge current can be adjusted from 0%-100% via a linear switch at the right of the battery type selector. This will be helpful if you are using our powerful charger on a small capacity battery bank. Fortunately, the linear switch can effectively reduce the max charging current to 20% of its peak.

Choosing "0" in the battery type selector will disable charging function.

There are mainly 3 stages:

Bulk Charging: This is the initial stage of charging. While Bulk Charging, the charger supplies the battery with controlled constant current. The charger will remain in Bulk charge until the Absorption charge voltage (determined by the Battery Type selection) is achieved.

Software timer will measure the time from A/C start until the battery charger reaches 0.3V below the boost voltage, then take this time as T0 and $T0 \times 2 = T1$.

Absorb Charging: This is the second charging stage and begins after the absorb voltage has been reached. Absorb Charging provides the batteries with a constant voltage and reduces the DC charging current in order to maintain the absorb voltage setting.

In this period, the inverter will start a T1 timer; the charger will keep the boost voltage in Boost CV mode until the T1 timer has run out. Then drop the voltage down to the float voltage. The timer has a minimum time of 1 hour and a maximum time of 12 hours.

Float Charging: The third charging stage occurs at the end of the Absorb Charging time. While Float charging, the charge voltage is reduced to the float charge voltage (determined by the Battery Type selection*). In this stage, the batteries are kept fully charged and ready if needed by the inverter.

If the A/C is reconnected or the battery voltage drops below 12Vdc/24Vdc/48Vdc, the charger will reset the cycle above.

If the charge maintains the float state for 10 days, the charger will deliberately reset the cycle to protect the battery.

Table 2.5.1 Battery Charging Processes

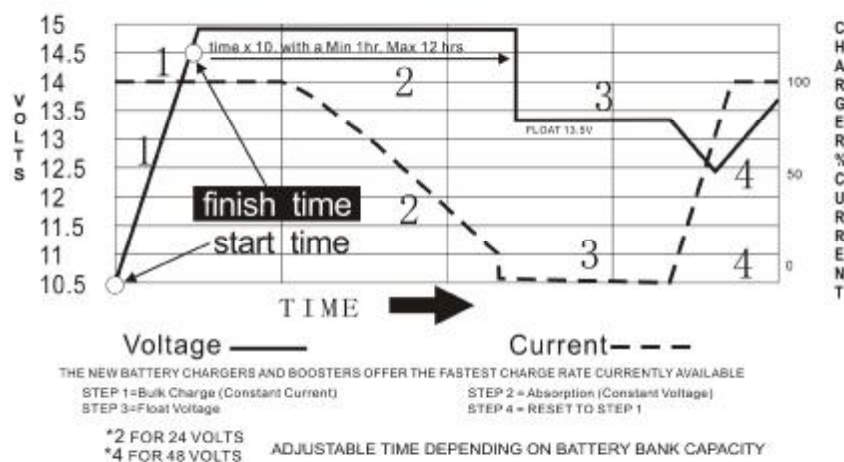

Table 2.5.2 Battery Type Selector

Switch Setting	Description	Fast Mode / VDC	Float Mode / VDC
0	Charger Off		
1	Gel USA	14.0	13.7
2	AGM 1	14.1	13.4
3	LiFePO4	14.6	13.7
4	Sealed Lead Acid	14.4	13.6
5	Gel EURO	14.4	13.8
6	Open Lead Acid	14.8	13.3

7	Calcium	15.1	13.6
8	De-sulphation	15.5 (4 Hours then Off)	

For 12Vdc Battery Mode (*2 for 24Vdc Mode ; *4 for 48Vdc Mode)

De-sulphation

The de-sulphation cycle on switch position 8 is marked in red because this is a very dangerous setting if you do not know what you are doing. Before ever attempting to use this cycle you must clearly understand what it does and when and how you would use it.

What causes sulphation? This can occur with infrequent use of the batteries(nor), or if the batteries have been left discharged so low that they will not accept a charge. This cycle is a very high voltage charge cycle designed to try to break down the sulfated crust that is preventing the plates taking a charge and thus allow the plates to clean up and so accept charge once again.

Charging depleted batteries

The XP series inverter allows start up and through power with depleted batteries.

For 12VDC model, after the battery voltage goes below 10V, if the switch is still (and always) kept in "ON" position, the inverter is always connected with battery, and the battery voltage does not drop below 2V, the inverter will be able to charge the battery once qualified AC inputs are present.

Before the battery voltage goes below 9VDC, the charging can be activated when the switch is turned to "Off", then to "ON".

When the voltage goes below 9VDC, and you accidently turn the switch to OFF or disconnect the inverter from battery, the inverter will not be able to charge the battery once again, because the CPU loses memory during this process.

Tabel 2.5.3 AC Charging Current for X model

Model Watt	Battery Voltage	AC Charger Current Max	Model Watt	Battery Voltage	AC Charger Current Max
1.000	12 Vdc	35 ± 5 Amp	2.000	12 Vdc	60 ± 5 Amp
	24 Vdc	20 ± 5 Amp		24 Vdc	30 ± 5 Amp
	48 Vdc	10 ± 5 Amp		48 Vdc	15 ± 5 Amp
3.000	12 Vdc	80 ± 5 Amp	4.000	12 Vdc	100 ± 5 Amp
	24 Vdc	45 ± 5 Amp		24 Vdc	55 ± 5 Amp
	48 Vdc	25 ± 5 Amp		48 Vdc	35 ± 5 Amp
5.000	24 Vdc	65 ± 5 Amp	6.000	24 Vdc	80 ± 5 Amp
	48 Vdc	40 ± 5 Amp		48 Vdc	50 ± 5 Amp
8.000	24 Vdc	100 ± 5 Amp	10.000	48 Vdc	80 ± 5 Amp
	48 Vdc	65 ± 5 Amp		12.000	48 Vdc

The charging capacity will go to peak in around 3 seconds. This may cause a generator to drop frequency, making inverter transfer to battery mode.

It is suggested to gradually put charging load on the generator by switching the charging switch from min to max, together with the 15s switch delay, our inverter gives the generator enough time to spin up. This will depend on the size of the generator and rate of charge.

2.5.3 Transfer

While in the Standby Mode, the AC input is continually monitored. Whenever AC power falls below the VAC Trip voltage (154 VAC, default setting for 230VAC,90VAC for 120VAC), the inverter automatically transfers back to the Inverter Mode with minimum interruption to your appliances - as long as the inverter is turned on. The transfer from Standby mode to Inverter mode occurs in approximately 8 milliseconds. And it is the same time from Inverter mode to Standby mode.

Though it is not designed as a computer UPS system, this transfer time is usually fast enough to keep your equipment powered up.

There is a 15-second delay from the time the inverter senses that continuously qualified AC is present at the input terminals to when the transfer is made. This delay is built in to provide time for a generator to spin-up to a stable voltage and avoid relay chattering. The inverter will not transfer to generator until it has locked onto the generator's output. This delay is also designed to avoid frequent switching when input utility is unstable.

2.5.4 Frequency adjust

The frequency of the inverter is arranged by the SW4. Refer to the Table 2.5.11.

The factory default configuration for 220/230/240VAC inverter is 50Hz, and 60Hz for 100/110/120VAC inverter. While the output freq can be easily changed once a qualified freq is applied to the inverter.

2.5.5 Solar Charger

Listed below is the spec for solar charger

Table 2.5.4 Solar Charge Electrical Specification @ 25°C

Rated Voltage	12Vdc	24Vdc	48Vdc
Rated Charge Current (Includes Load Current)	40/60Amp		40Amp
Load Ccurrent	15Amp		
Input Voltage Range	15-45Vdc	30-70Vdc	60-100Vdc
Max. PV Open Circuit Array Voltage	45Vdc	70Vdc	100Vdc
Overload Protection (DC load)	2.0 * I(Rated)>5s ; 1.5 * I(Rated) >20s 1.25 * I(Rated) Temperature Controlled		
Typical Idle Consumption	At idle < 10mA		
Bulk Charge	14.6Vdc	29.2Vdc	58.4Vdc
Floating Charge	13.4Vdc	26.8Vdc	53.6Vdc
Equalization Charge	14.0Vdc	28.0Vdc	58.0Vdc
Over Charge Disconnect	14.8Vdc	29.6Vdc	59.2Vdc
Over Charge Recovery	13.6Vdc	27.2Vdc	54.4Vdc
Over Discharge Disconnect	10.8Vdc	21.6Vdc	43.2Vdc
Over Discharge Reconnect	12.3Vdc	24.6Vdc	49.6Vdc
Temperature Compensation	-13.2mV/°C	-26.4mV/°C	-52.8mV/°C
Lead Acid Battery Settings	Adjustable		
NiCad Battery Settings	Adjustable		

Low Voltage Reconnect	12.0-14.0Vdc	24.0-28.0Vdc	48.0-56.0Vdc
Low Voltage Disconnect	10.5-12.5Vdc	21.0-25.0Vdc	42.0-50.0Vdc
Ambient Temperature	0-40°C (Full load) 40-60°C (De-rating)		
Altitude	Operating 5000m, Non-Operating 16000m		
Battery Temperature Sensor①	BTS (Optional) Remote Battery Temperature Sensor for Increased Charging Precision		
Terminal Size (Fine/Single Wire)	#8 AWG		

NOTE:

①The optional battery temperature sensor automatically adjusts the charging process of the controller according to the type of battery that is selected by user through battery type selector. With the battery temperature sensor installed, the controller will increase or decrease the battery charging voltage depending on the temperature of the battery to optimize the charge to the battery and maintain optional performance of the battery.

Maximum Power Point Tracking (MPPT) Function

Maximum Power Point Tracking, frequently referred to as MPPT, is an electronic system that operates the Photovoltaic (PV) modules in a manner that allows the modules to produce all the power they are capable of. The PV-seeker Charge controller is a microprocessor-based system designed to implement the MPPT.

And it can increase charge current up to 30% or more compared to traditional charge controllers (See Table 2.5.4).

Table 2.5.5 Current, Power Vs. Voltage Characteristics

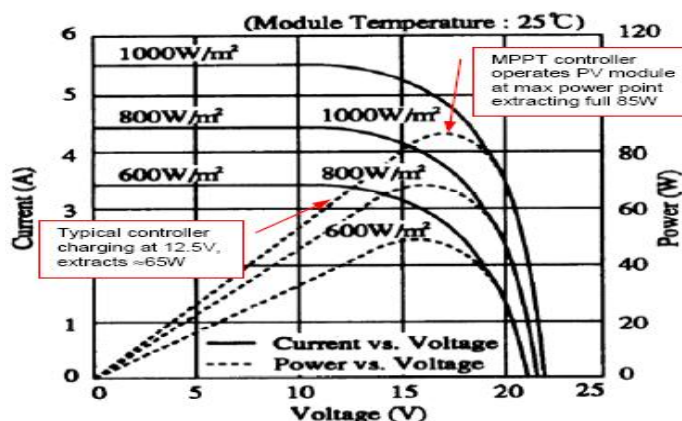

The Charge controller built in is with 12/24/48V battery voltage auto detecting function.

For 12/24VDC inverter, the output voltage of solar charger will be accordingly 12/24VDC, and the qualified DC input volt range is 15 -70VDC.

For 48VDC inverter, the output voltage of solar charger will be accordingly 48VDC, and the qualified DC input volt range is 60 -100VDC.

If the voltage falls out of this range, the charger will not work properly. Special attention should be paid to this when configuring the solar array.

2.5.6 Automatic Voltage Regulation(Optional)

The automatic voltage regulation function is for full series of X series Pure Sine Wave Inverter/ Charger except split phase models including X1000W~6000W.

Instead of simply bypassing the input AC to power the loads, the XPS series inverter stabilizes the input AC voltage to a range of 230V/120V±10%.

Connected with batteries, the XS Series inverter will function as a UPS with max transfer time of 10 ms. With all the unique features our inverter provides, it will bring you long-term trouble free operation beyond your expectation.

Function Introduction

Table 2.5.5 Input Voltage Transfer Points

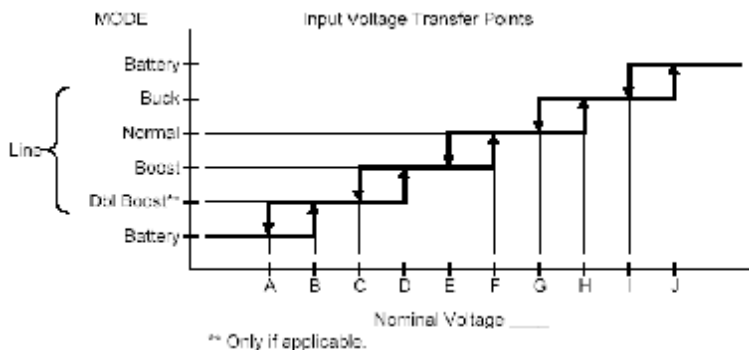

XPS Function (Optional)	XPS Series					
	LV (NA/JPN)			HV (INTL)		
Acceptable Input Voltage Range (Vac)	0-160			0-300		
Nominal Input Voltages (Vac)	100	110	120	220	230	240
(A) Line low loss N/W (On battery)	75/65	84/72	92/78	168/143	176/150	183/156
(B) Line Low comeback N/W (On Boost)	80/70	89/77	97/83	178/153	186/160	193/166
(C) Line 2nd boost threshold (On Boost)	**	**	**	**	**	**
(D) Line 2nd boost comeback (On Normal)	**	**	**	**	**	**
(E) Line 1st boost threshold (On Boost)	90	99	108	198	207	216
(F) Line 1st boost comeback (On Normal)	93	103	112	205	215	225
(G) Line buck comeback (On Normal)	106	118	128	235	246	256
(H) Line buck threshold (On Buck)	110	121	132	242	253	264
(I) Line high comeback (On Buck)	115	127	139	253	266	278
(J) Line high loss (On Battery)	120	132	144	263	276	288

2.5.7 Power Saver Mode

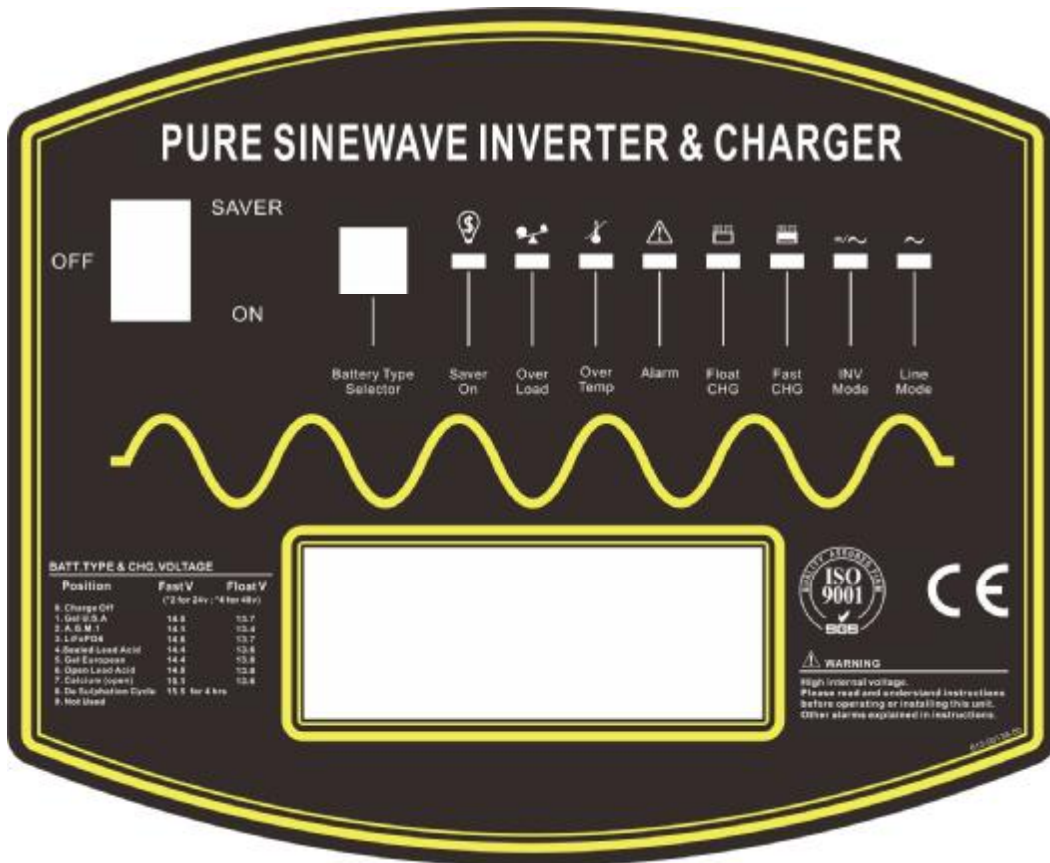

There are 3 different working status for X series inverter: “Power Saver Auto” 、 “Power Saver Off” and “Power Off”. When power switch is in “Unit Off” position, the inverter is powered off. When power switch is turned to either of “Power Saver Auto” or “Power Saver Off”, the inverter is powered on. Power saver function is designed to conserve battery power when AC power is not or rarely required by the loads. In this mode, the inverter pulses the AC output looking for an AC load (i.e., electrical appliance). Whenever an AC load (greater than 25 watts) is turned on, the inverter recognizes the need for power and automatically starts inverting and output goes to full voltage. When there is no load (or less than 25 watts) detected, the inverter automatically goes back into search mode to minimize energy consumption from the battery bank. In “Power saver on” mode, the inverter will draw power mainly in sensing moments, thus the idle consumption is significantly reduced.



Note: The minimum power of load to take inverter out of sleep mode (Power Saver On) is 25 Watts.

Table 2.5.6 X Series Idle Power Consumption

Model	Power Saver Off	Power Saver Auto	
	Idle(Max)	3Secs(Max)	Stand-By Mode
1.0KW	18W	7.5W	2.5W
1.5KW	18W	7.5W	
2.0KW	30W	10.0W	
3.0KW	60W	15.0W	
4.0KW	70W	20.0W	
5.0KW	80W	25.0W	
6.0KW	90W	25.0W	
8.0KW	120W	30.0W	
10.0KW	150W	35.0W	
12.0KW	180W	40.0W	

When in the search sense mode, the green power LED will blink and the inverter will make a ticking sound. At full output voltage, the green power LED will light steadily and the inverter will make a steady humming sound. When the inverter is used as an “Un-interruptible power supply” the search sense mode or “Power Saver On” function should be defeated.

Exceptions

Some devices when scanned by the load sensor cannot be detected. Small fluorescent lights are the most common example. (Try altering the plug polarity by turning the plug over.) Some computers and sophisticated electronics have power supplies that do not present a load until line voltage is available. When this occurs, each unit waits for the other to begin. To drive these loads either a small companion load must be used to bring the inverter out of its search mode, or the inverter may be programmed to remain at full output voltage.

2.5.8 Protections

The XP series inverter is equipped with extensive protections against various harsh situations/faults.

These protections include:

AC Input over voltage protection/AC Input low voltage protection

Low battery alarm/High battery alarm

Over temperature protection/Over load protection

Short Circuit protection (1sec after fault)

Back feeding protection

When Over temperature /Over load occur, after the fault is cleared, the master switch has to be reset to restart the inverter.

The Low batter voltage trip point can be customized from defaulted value 10VDC to 10.5VDC turn the SW1 on DIP switch.

The inverter will go to Over temp protection when heat sink temp. $\geq 105^{\circ}\text{C}$, and go to Fault (shutdown Output) after 30 seconds. The switch has to be reset to activate the inverter.

The X series Inverter has back feeding protection which avoids presenting an AC voltage on the AC input terminal in Invert mode.

After the reason for fault is cleared, the inverter has to be reset to start working.

2.5.9 Remote control Module

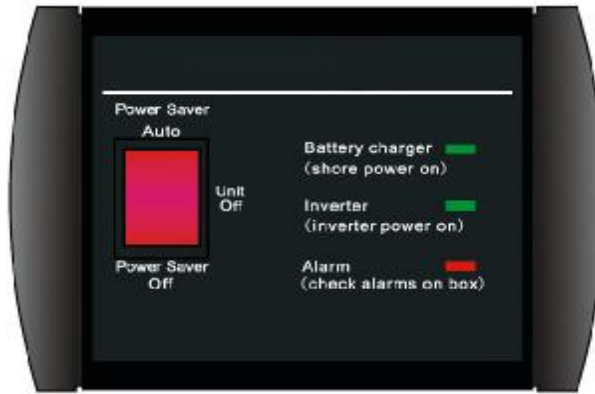

Apart from the switch panel on the front of the inverter, an extra switch panel connected to the RJ11 port at the DC side of the inverter thru a standard telephone cable can also control the operation of the inverter.

If an extra switch panel is connected to the inverter via “remote control port”, together with the panel on the inverter case, the two panels will be connected and operated in parallel.

Whichever first switches from “Off” to “Power saver off” or “Power saver on”, it will power the inverter on.

If the commands from the two panels conflict, the inverter will accept command according to the following priority:

Power saver on> Power saver off> Power off

Only when both panels are turned to “Unit Off” position will the inverter be powered off.

The Max length of the cable is 10 meters.



WARNING

Never cut the telephone cable when the cable is attached to inverter and battery is connected to the inverter. Even if the inverter is turned off. It will damage the remote PCB inside if the cable is short circuited during cutting.

2.5.10 LED Indicator & LCD

Table 2.5.7 X Series LED Indicators

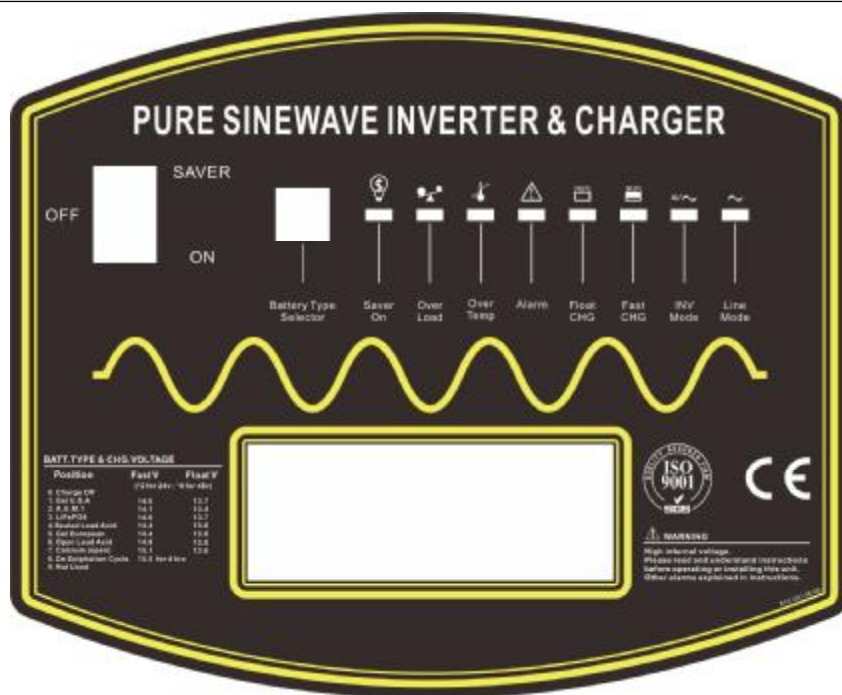

LINE MODE	GREEN LED lit in AC Mode	Please refer to 'Indicator and Buzzer' for the detailed information.
INVERTER MODE	GREEN LED lit in Inverter Mode	
FAST CHARGE	YELLOW LED lit in Fast Charging Mode	
FLOAT CHARGE	GREEN LED lit in Float Charging Mode	
ALARM MODE	RED LED lit in Error State	
OVER TEMP TRIP	RED LED lit in Over Temperature	
OVER LOAD TRIP	RED LED lit in Over Load	
POWER SAVER ON	GREEN LED lit in Power Saver Mode	

Table 2.5.8 X Series LCD Indicator

<p>1 Greeting message</p>	<p>2 AC Status & Input Voltage</p>
<p>3 Output Voltage/Frequency & Battery voltage</p>	<p>4 Output Current/Load(in percentage)</p>

2.5.11 Audible Alarm

Table 2.5.9 X Series Audible Alarm Spec

Battery Voltage Low	Inverter green LED lit, and the buzzer beeps 0.5s every 5s.
Battery Voltage High	Inverter green LED lit, and the buzzer beeps 0.5s every 1s and Fault after 60s.
Invert Mode Over-Load	(1)110%<load<125%(±10%), No audible alarm in 14 minutes, Beeps 0.5s every 1s in 15 th minute and Fault after 15 minutes; (2)125% <load<150%(±10%), Beeps 0.5s every 1s and Fault after 60s; (3)Load>150%(±10%), Beeps 0.5s every 1s and Fault after 20s;
Over Temperature	Heat-sink temp. ≥105°C, Over temp red LED Lighting, beeps 0.5s every 1s;

2.5.12 FAN Operation

For 1-3KW, there is one multiple controlled DC fan, For 4-6KW, there is two multiple controlled DC fan which starts to work according to the following logic

For 8-12KW, there is two multiple controlled DC fan and one AC fan. The DC fan will work in the same way as the one on 1-3KW, while the AC fan will work once there is AC output from the inverter.

So when the inverter is in power saver mode, the AC fan will work from time to time in response to the pulse sent by the inverter in power saver mode.

The Operation of the DC fan at the DC terminal side is controlled by the following logic
(Refer to Table 2.5.10):

Table 2.5.10 X Series Fan Operation Logic

Condition	Enter condition	Leave condition	Speed
HEAT SINK TEMPERATURE	$T \leq 60^{\circ}\text{C}$	$T > 65^{\circ}\text{C}$	Off
	$65^{\circ}\text{C} \leq T < 85^{\circ}\text{C}$	$T \leq 60^{\circ}\text{C} / T \geq 85^{\circ}\text{C}$	50%
	$T > 85^{\circ}\text{C}$	$T \leq 80^{\circ}\text{C}$	100%
CHARGER CURRENT	$I \leq 15\%$	$I \geq 20\%$	Off
	$20\% < I \leq 50\%$	$I \leq 15\% / I \geq 50\%$	50%
	$I > 50\%$	$I \leq 40\%$	100%
LOAD% (INV MODE)	Load < 30%	Load ≥ 30%	Off
	$30\% \leq \text{Load} < 50\%$	Load ≤ 20% / Load ≥ 50%	50%
	Load ≥ 50%	Load ≤ 40%	100%

Allow at least 30cm of clearance around the inverter for air flow. Make sure that the air can circulate freely around the unit.

Variable speed fan operation is required in inverter and charge mode. This is to be implemented in such a way as to ensure high reliability and safe unit and component operating temperatures in an operating ambient temperature up to 50°C.

- Speed to be controlled in a smooth manner as a function of internal temperature and/or current.
- Fan should not start/stop suddenly.
- Fan should run at minimum speed needed to cool unit.
- Fan noise level target <60db at a distance of 1m.

2.5.13 DIP Switches

On the front panel of inverter, there are 5 DIP switches which enable users to customize the performance of the device.

Table 2.5.11 X Series Dip Switch Function Setting

DIP Switch NO.	Switch Function	Position: 0	Position: 1
SW1	Low Battery Trip Volt	10.0Vdc For Deep-Cycle Battery	10.5Vdc For Starting Battery
		*2 for 24Vdc, *4 for 48Vdc	
SW2	AC Input Range / (AVR)	AC Source	For Utility Mode
		230Vac HV	For Generator Mode
		120Vac LV	
		184-253Vac / (176-276Vac)	140-270Vac / (150-276Vac)
		100-135Vac / (92-144Vac)	90-135Vac / (78-144Vac)
SW3	Power Saver Auto Setting	Night Charger Function	Detect Load Per 3Secs
SW4	O/P Frequency Setting	50Hz	60Hz
SW5	Solar/AC Priority Setting	Utility Priority	Battery Priority

SW1: Low Battery Trip Volt:

For 12VDC model, the Low Battery Trip Volt is set at 10.0Vdc by typical deep cycle lead acid battery. It can be customized to 10.5Vdc using SW1 for sealed car battery, this is to prevent batteries from over-discharging while there is only a small load applied on the inverter. (*2 for 24VDC, *4 for 48VDC)

SW2: AC Input Range:

There are different acceptable AC input ranges for different kinds of loads.

For some relatively sensitive electronic devices, a narrow input range of 184-253VAC (100-135V for 120VAC model) is required to protect them.

While for some resistive loads which work in a wide voltage range, the input AC range can be customized to 140-270VAC (90-135V for 120VAC model), this helps to power loads with the most AC input power without frequent switches to the battery bank.

In order to make the inverter accept dirty power from a generator, when the SW2 is switched to position "1", the inverter will bypass an AC input with a wide voltage and frequency (40Hz-70Hz for 50Hz/60Hz).

Accordingly, the AC charger will also work in a wide voltage and frequency range (43Hz-67Hz for 50Hz/60Hz). This will avoid frequent switches between battery and generator. But some sensitive loads will suffer from the low quality power.

The pros and cons should be clearly realized.

SW3: Power Saver Auto Setting :

In Power Saver Mode, when the SW3 is switched to position "0", inverter will work in Unit Off Charging mode, it will stay in standby mode without sensing loads. It won't output any power even if a load is turned on. The inverter will not perform any function and only stay idle in this mode. When a qualified AC input present, it will switch to AC input power to charge the battery and supply the load at the same time.

When the SW3 is switched to position "0", the inverter is initially in standby mode and sends a pulse to detect the presence of a load every 3 seconds. Each pulse lasts for 250ms. The inverter will remain in standby mode until a load has been detected. Then it will wake up from standby mode and start to inverter electricity from the battery bank to supply the load.

SW4: Frequency Switch:

The output frequency of the inverter can be set at either 50Hz or 60Hz by SW4.

SW5: Solar Mode/AC Mode Priority:

Our inverter is designed with AC priority by default. This means, when AC input is present, the battery will be charged first, and the inverter will transfer the input AC to power the load. Only when the AC input is stable for a continuous period of 15 days, the inverter will start a battery inverting cycle to protect the battery. After 1 normal charging cycle ac through put will be restored.

The AC Priority and Battery Priority switch is SW5. When you choose battery priority, the inverter will inverting from battery despite the AC input. Only when the battery voltage is reaches low voltage alarm point(10.5V for 12V), the inverter transfers to AC Input, charge battery, and switch back to battery when battery is charged full. This function is mainly for wind/solar systems taking utility power as back up.

2.5.14 Output Socket

The inverter is either equipped with a dual GFCI socket (rated at 30Amps) or an universal socket (rated at 10Amps) for more convenient wiring.

2.5.15 Other features

Battery voltage recovery start

After low battery voltage shut off (10V for 12V model/20V for 24V model/40V for 48V model), the inverter is able to restore operation after the battery voltage recovers to 13Vdc/26Vdc/52Vdc (with power switch still in the "On" position). This function helps to save the users extra labor to reactivate the inverter when the low battery voltage returns to an acceptable range in the renewable energy systems. The built in battery charger will automatically reactivate as soon as city/generator ac has been stable for 15 seconds.



WARNING

Never leave the loads unattended, some loads (like a Heater) may cause accident in such cases. It is better to shut everything down after low voltage trip than to leave your load on, due to the risk of fire.

Auto Generator Start (AGS)

The inverter can be customized to start up a generator when battery voltage goes low.

When the inverter goes to low battery alarm, it can send a signal to start a generator, and turn the generator off after battery charging is finished.

The auto generator start feature will only work with generators designed to work with this feature. There is an open/closed relay that will short circuit the positive and negative cable from a generator. The input DC voltage can vary, but the Max current the relay can carry is 16Amp.

Battery temperature sensor (BTS)

A battery temperature sensor (BTS) option can easily be installed in the system to ensure proper charging of the batteries based on temperature. Installing a BTS extends battery life by preventing overcharging in warm temperatures and undercharging in cold temperatures.

To install the Battery Temperature Sensor:

1. Run the battery temperature sensor wire in the DC conduit (if used) and route the RJ11 connector end to the BATTERY SENSE port located on the front of the inverter.
2. Secure the sensor to one of the batteries located in the center of the battery pack.

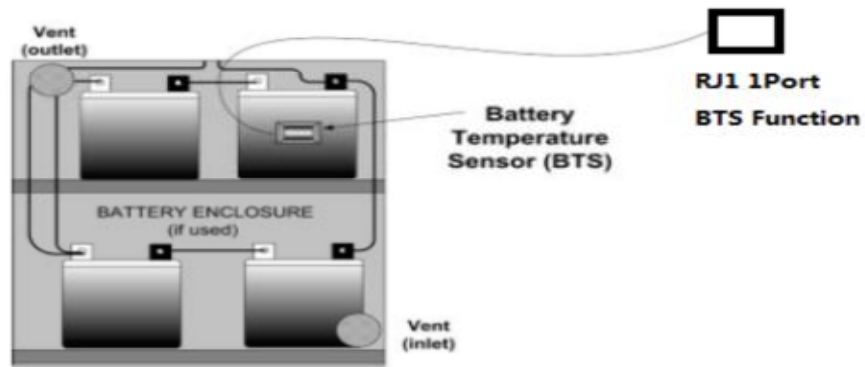

Conformal Coating

Entire line of XP series inverters have been processed with a conformal coating on the PCB making it water, rust, and dust resistant.

3 Installation

3-1 Location

Follow all the local regulations to install the inverter.

Please install the equipment in a location that is Dry, Clean, Cool and that has good ventilation.

Working temperature: - 10°C - 40°C

Storage temperature: - 40 - 70°C

Relative Humidity: 0% - 95%, non-condensing

Cooling: Forced air

3-2 DC Wiring recommendation

It is suggested the battery bank be kept as close as possible to the inverter. The following table is a suggested wiring option for 1m DC cable.

Please find the following minimum wire size. In case of DC cable longer than 1m, please increase the cross section of cable to reduce the loss.

Model Watt	Battery Voltage	Wire Gage /Min		Model Watt	Battery Voltage	Wire Gage /Min	
		0~1.0m	1.0~5.0m			0~1.0m	1.0~5.0m
1.000 ~ 1.500	12 Vdc	30mm ²	40mm ²	2.000	12 Vdc	60mm ²	75mm ²
	24 Vdc	15mm ²	20mm ²		24 Vdc	30mm ²	45mm ²
	48 Vdc	10mm ²	15mm ²		48 Vdc	15mm ²	25mm ²
3.000	12 Vdc	90mm ²	120mm ²	4.000	12 Vdc	120mm ²	150mm ²
	24 Vdc	45mm ²	60mm ²		24 Vdc	60mm ²	75mm ²
	48 Vdc	25mm ²	30mm ²		48 Vdc	30mm ²	40mm ²
5.000	24 Vdc	75mm ²	95mm ²	6.000	24 Vdc	90mm ²	120mm ²
	48 Vdc	40mm ²	50mm ²		48 Vdc	45mm ²	60mm ²
8.000	24 Vdc	120mm ²	150mm ²	10.000	48 Vdc	75mm ²	95mm ²
	48 Vdc	60mm ²	75mm ²	12.000	48 Vdc	90mm ²	120mm ²

Please note that if there is a problem obtaining for example 100mm² cable, use 2*50mm² or 3*35mm².

One cable is always best, but cable is simply copper and all you require is the copper, so it does not matter if it is one cable or 10 cables as long as the square area adds up. Performance of any product can be improved by thicker cable and shorter runs, so if in doubt round up and keep the length as short as possible.

Battery cables must have crimped (or preferably, soldered and crimped) copper compression lugs unless aluminum mechanical lugs are used. Soldered connections alone are not acceptable. High quality, UL-listed battery cables are available. These cables are color-coded with pressure crimped, sealed ring terminals.

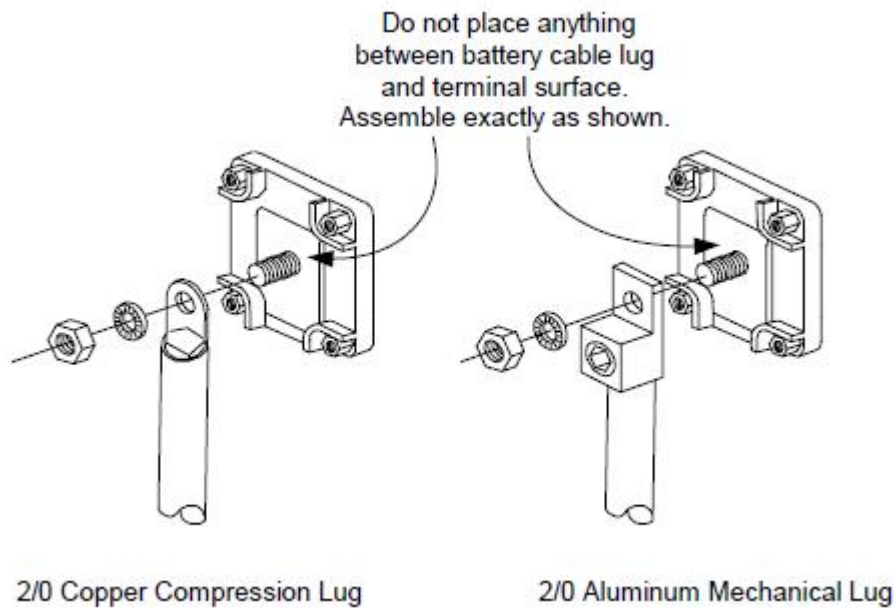
Figure 3.2.1 Battery Cable Connections**CAUTION: Equipment Damage**

The inverter is not reverse polarity protected. Reversing the battery polarity on the DC input connections will cause permanent damage to the inverter which is not covered under warranty. Always check polarity before making connections to the inverter.

**WARNING: Shock Hazard**

Ensure the inverter is off before disconnecting the battery cables, and that AC power is disconnected from the inverter input.

Battery terminal must be clean to reduce the resistance between the DC terminal and cable connection. A buildup of dirt or oxidation may eventually lead to the cable terminal overheating during periods of high current draw. Use a stiff wire brush and remove all dirt and corrosion from the battery terminals and cables.

3-3 AC Wiring

We recommend using 10-5AWG wire to connect to the AC terminal block.

There are 3 different ways of connecting to the terminal block depending on the model. All the wirings are CE compliant, Call our tech support if you are not sure about how to wire any part of your inverter.

Single-Phase Wiring Mode

230Vac or 120Vac

Input: Hot line+Neutral+Ground
Output: Hot line+Neutral+Ground

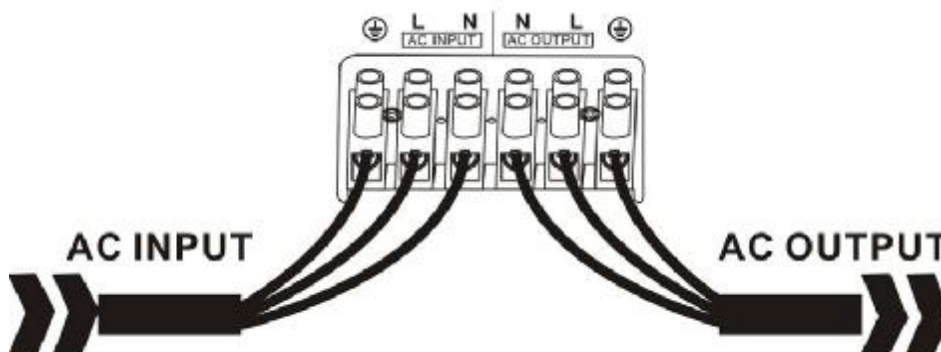

Daul-Phase Wiring Mode

240Vac split phase

Input: Hot line+ Hot line +Ground
Output: Hot line+ Hot line +Neutral

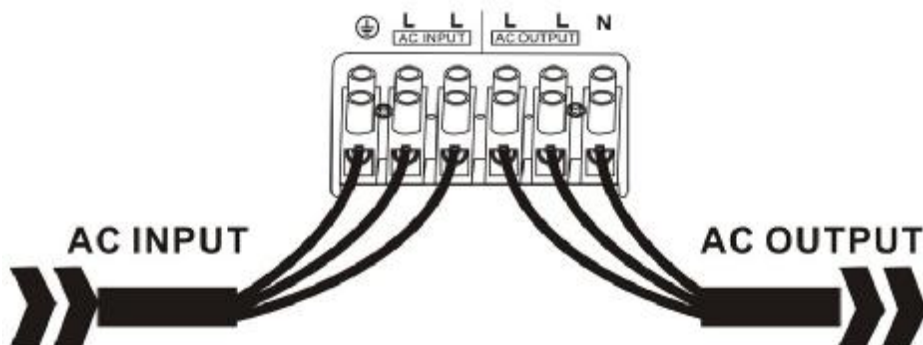

Wiring Option 3

120Vac split phase

Input: Hot line+ Hot line +Ground

Output: Hot line +Neutral+Ground

Remark: In such cases, each output hot line can only carry a half the rated capacity Max.

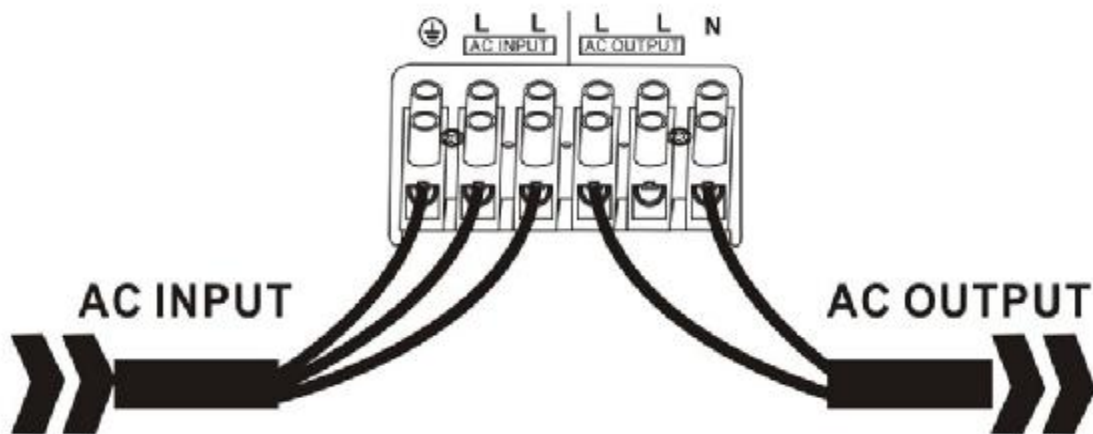
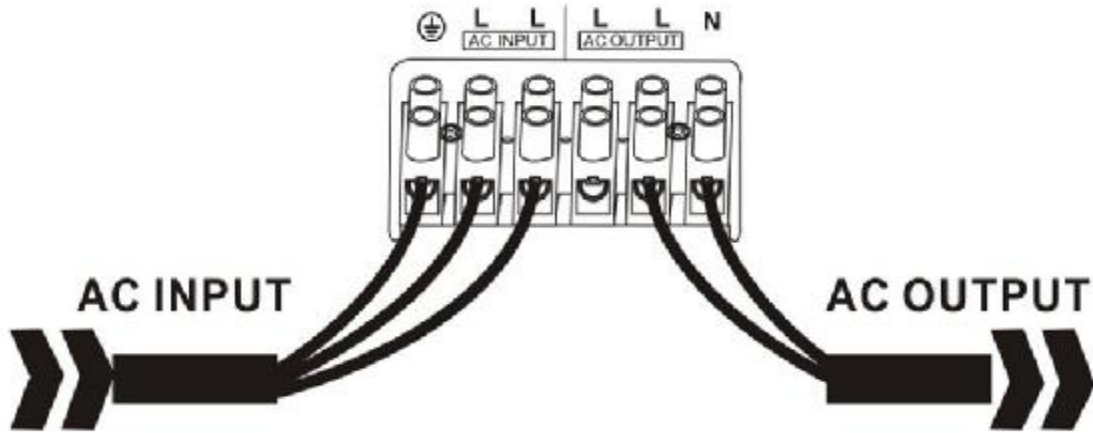

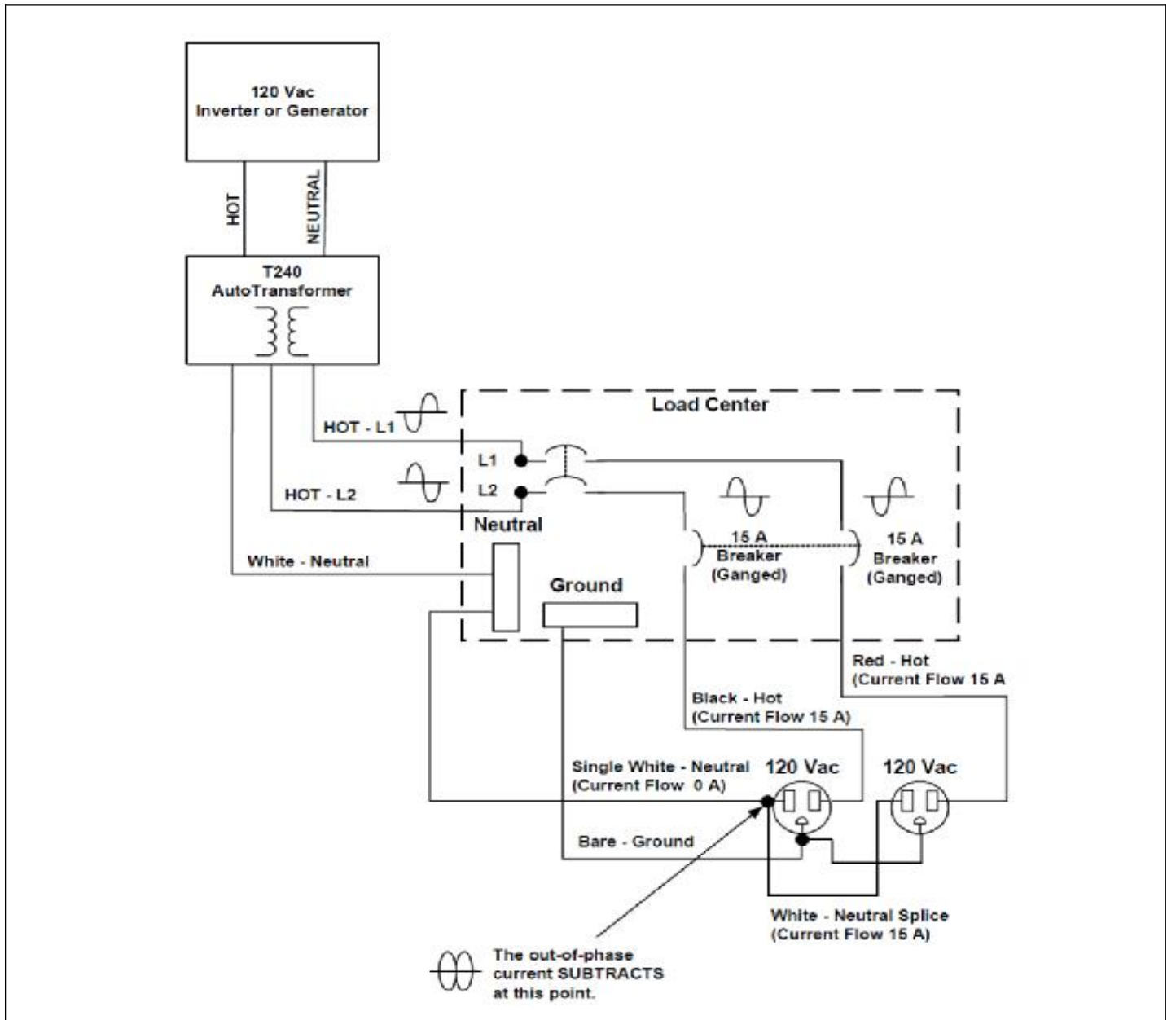

3-4 Install Flange

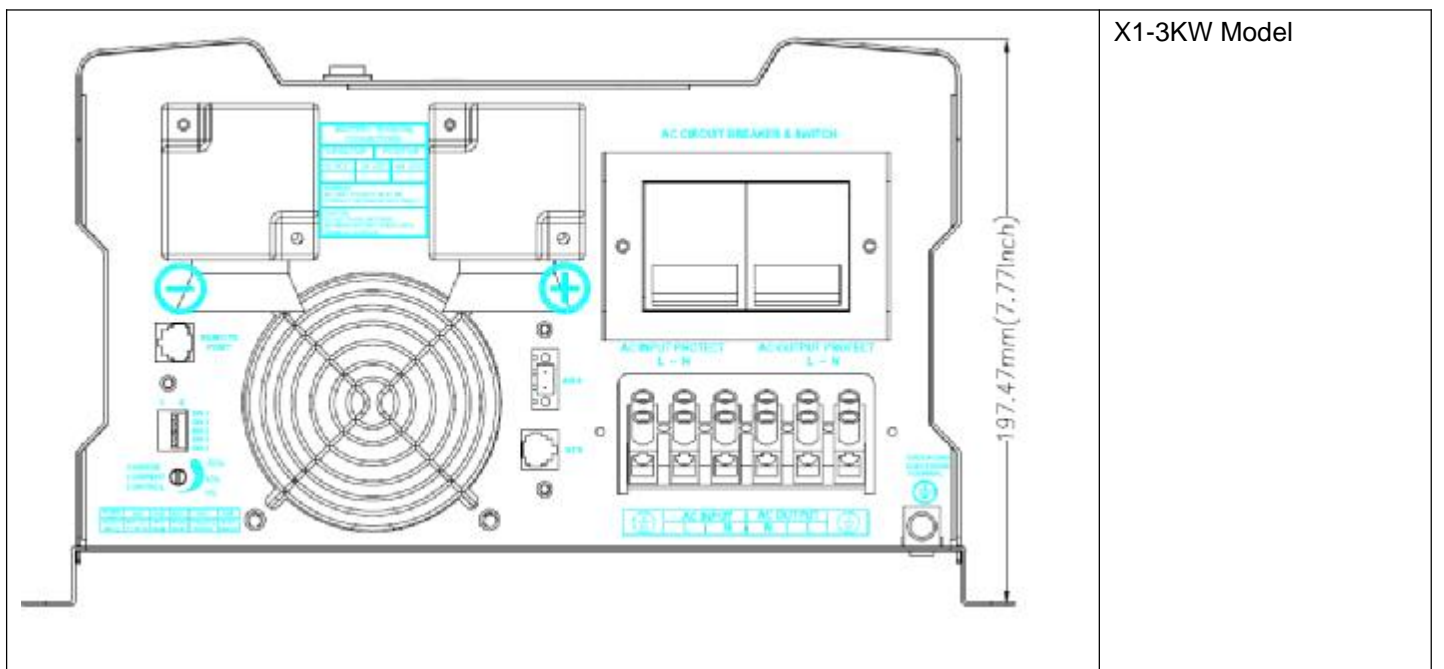

X1-3KW Model

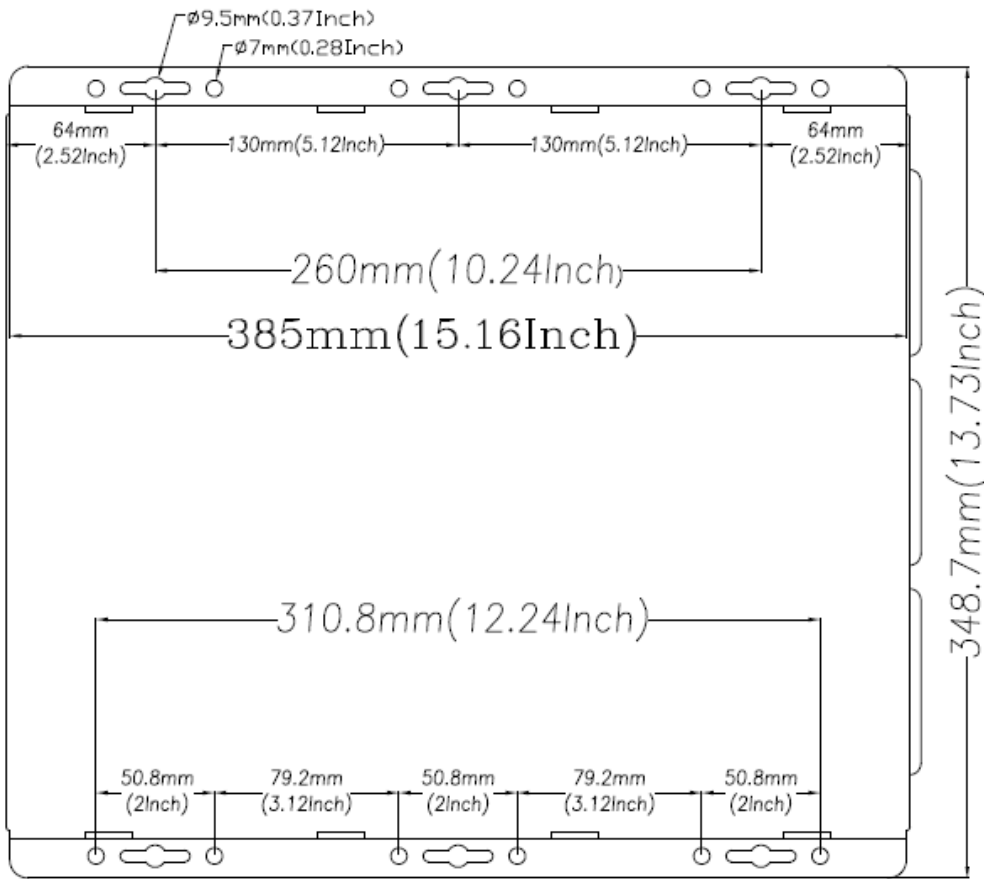

X4-6KW Model
 XP1-6KW Model
 X8-12KW Model
 XP8-12KW Model

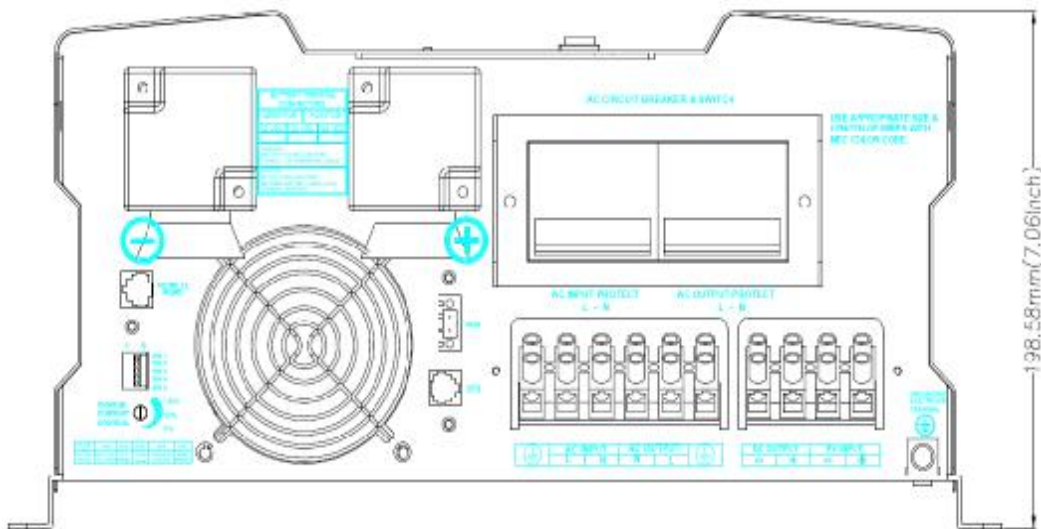

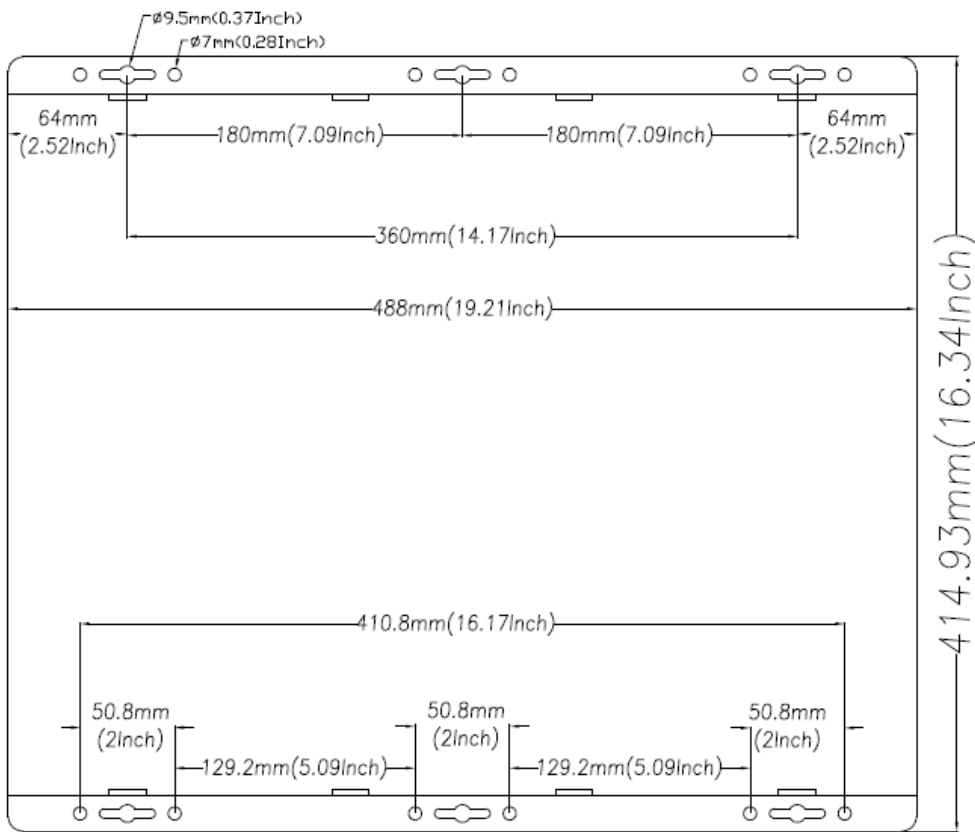

X4-6KW Model
XP1-6KW Model

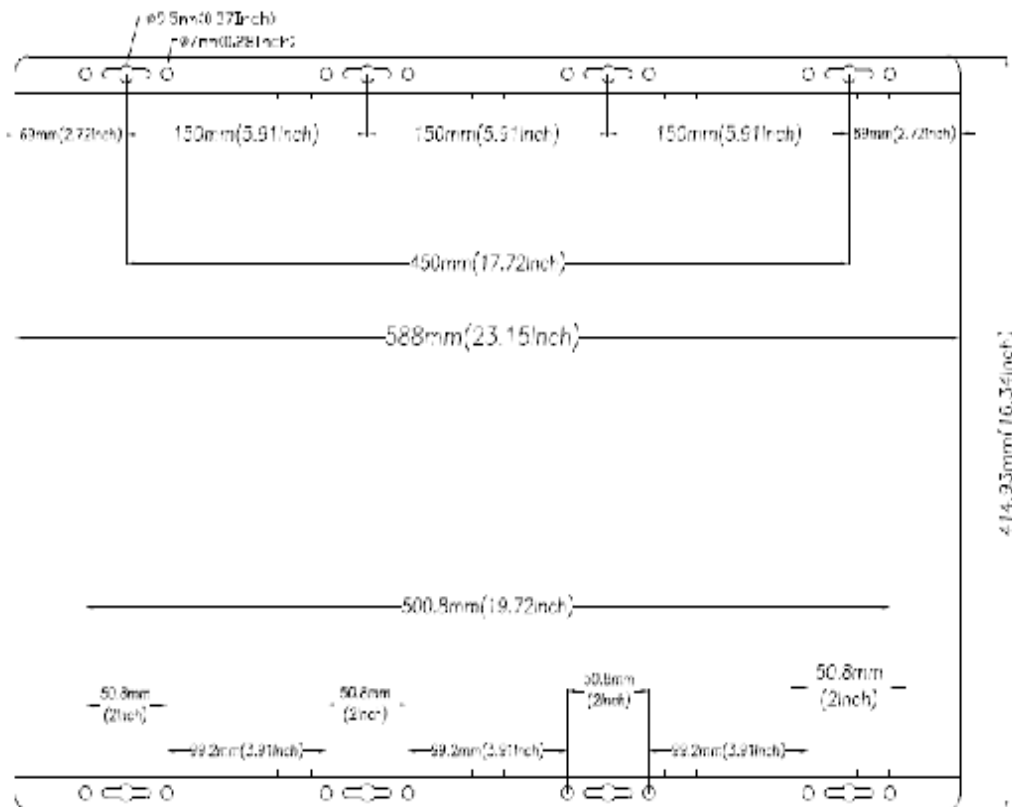

X8-12KW Model
XP8-12KW Model

4 Battery Information

4-1 Battery Type

There are two principal types of batteries: Starting type and Deep-Discharge type. Batteries can be either sealed or non-sealed(Vented).

A. Starting type: Automotive(Starting type) batteries are designed to provide high starting current for short periods of time and are not appropriate for solar system.

B. Deep-Discharge type: The battery types recommended for use in the inverter system are Flooded Lead Acid

- * Sealed construction, safety and no leakage
- * Maintenance-free, convenient for installation
- * Broad operating temperature range
- * High capacity, high energy density
- * Long service life, Excellent recharge and discharge performance
- * Low self-discharge rate, more deep cycle times

4-2 Battery Capacity Rating

4.2.1 Battery Discharge Rate

Deep cycle batteries have their amp-hour rating expressed as “at the x-hour rate”.

The hour rating refers to the time it takes to discharge the batteries. A faster hour rate (10 hour rate) means more current is withdrawn from the batteries during their discharge period. There is an inevitable amount of heat associated with the flow of current through a battery and the higher amount of current the greater the amount of heat will be generated. The heat is energy which is no longer available to the battery to power loads. a relatively long discharge rate (120 hour rate) will result in a larger number of amp-hours being available for electrical loads.

4.2.2 Depth of Discharge

The battery bank's size determines the length of time the inverter can supply AC output power. The larger the bank, the longer the inverter can run.

In general, the battery bank should be designed so the batteries do not discharge more than 60% of their capacity on a regular basis. Discharging up to 80% is acceptable on a limited basis, such as a prolonged utility outage. Totally discharging a battery can reduce its effective life or permanently damage it.

4.2.3 Understanding Amp-Hour Requirements

To estimate the battery bank requirements, you must first calculate the amount of power you will draw from the batteries during your period of autonomy. This power draw is then translated into Amp-Hours (Ah)

the unit of measure to express deep-cycle battery capacity.

Amp Hours are calculated multiplying the current drawn by the load by the length of time it will operate.

To calculate amps when the power consumption is expressed in watts, use the following equation:

$$A = P/V$$

$$P = \text{Watts} ; V = \text{Volts DC} ;$$

For example:

A 60 watt light bulb will draw approximately 5.0 Amps.

5.0 = 60 /12

If the light runs for three hours it will consume (5.0 x 3) or 15 Ah of power.

The length of time a load is operated will affect the power draw. In some cases, an appliance which draws a large wattage may not consume as many amp hours as a load drawing fewer watts but running for a longer period of time.

For Example:

A circular saw draws 1500 watts or 125 amps. It takes 5 seconds to complete a cross cut. Twelve such cuts would take a minute and you would consume $125A \times 0.016^* \text{ hour} = 2 \text{ Ah}$. (*0.016 = 1/60)

Suggestion :

All electrical appliances have labels which state their energy consumption. Look for an amps rating on motors and a watts rating on other appliances. If the label plate has expressed power consumption in amps, multiply by volts for the watts required. (watts = volts x amps).

When calculating battery bank size, consider the following:

Motors typically require 3 to 6 times their running current when starting. Check the manufacturer's data sheets for their starting current requirements. If you will be starting large motors from the inverter, increase the battery bank size to allow for the higher start-up current.

4.2.4 Battery Configurations

The battery bank must be wired to match the inverter's DC input voltage specifications (12 or 24 or 48Vdc). In addition, the batteries can be wired to provide additional run time.

Series : Wiring batteries in series increases the total bank output voltage. This voltage **MUST** match the DC requirements of the inverter or inverter and/or battery damage may occur.

Parallel: Wiring the batteries in parallel increases the total run time the batteries can operate the AC loads. The more batteries connected in parallel the longer the loads can be powered from the inverter.

Series-Parallel : Series-parallel configurations increase both the battery voltage (to match the inverter's DC requirements) and run-time for operating the AC loads. This voltage must match the DC requirements of the inverter. Batteries with more than two or three series strings in parallel often exhibit poor performance characteristics and shortened life.

4.2.5 Wiring Batteries

Table 4.2.1 Battery Wiring In Series Configuration

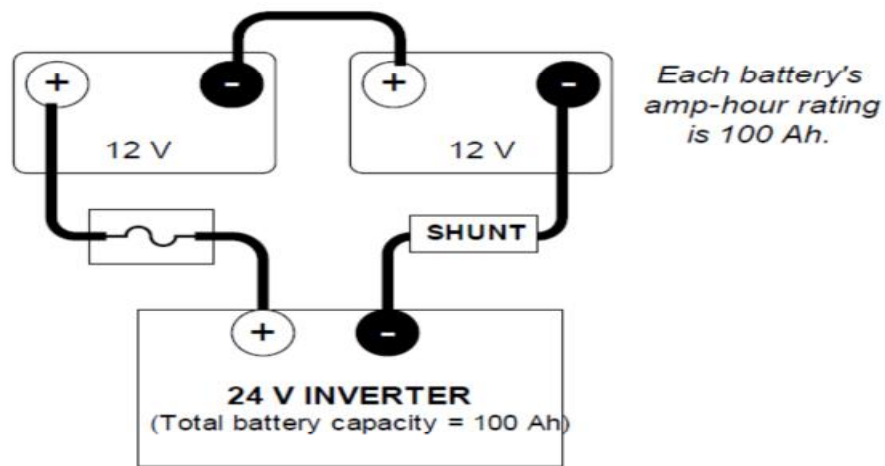
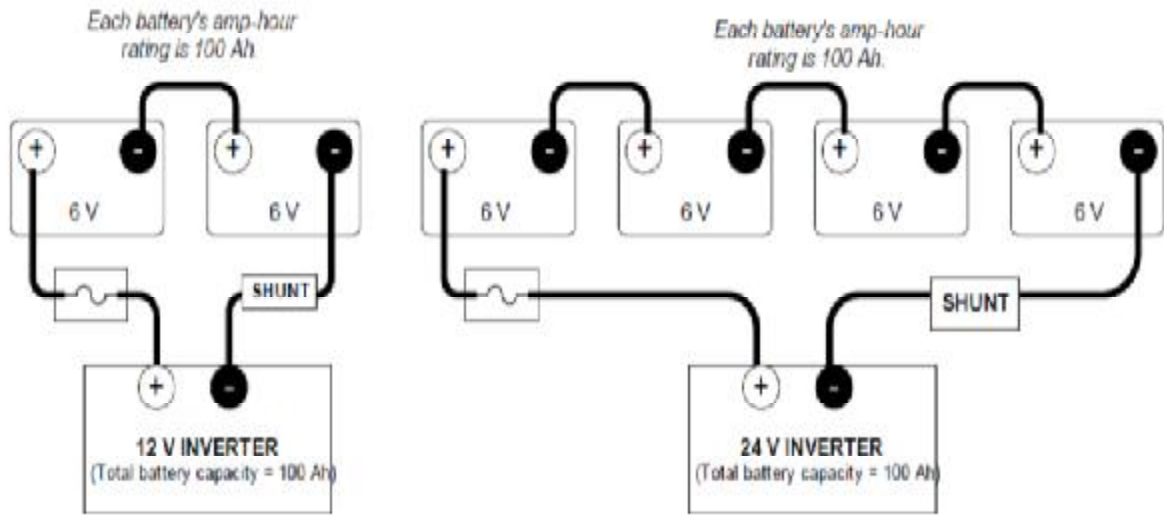

Table 4.2.2 Battery Wiring In Parallel Configuration

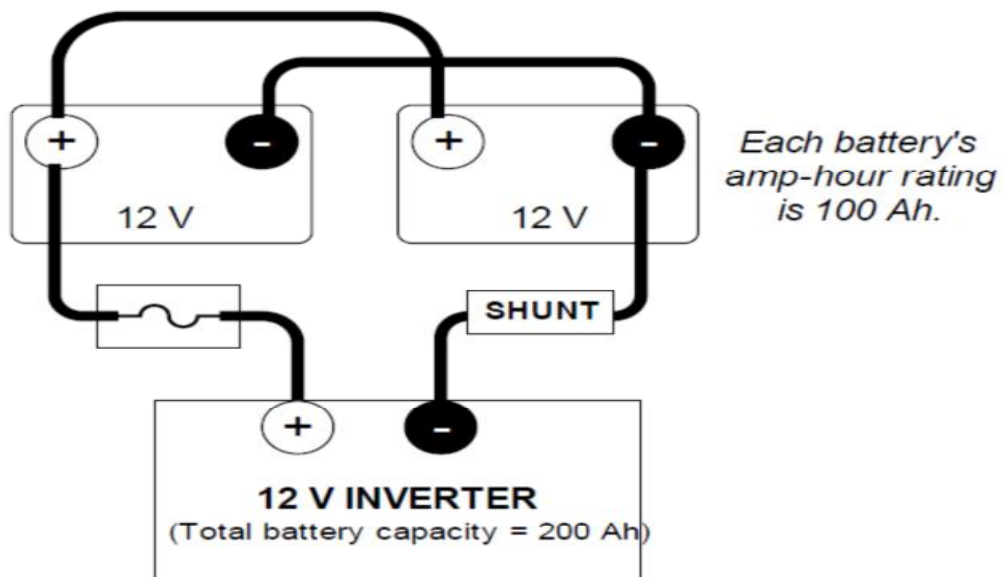
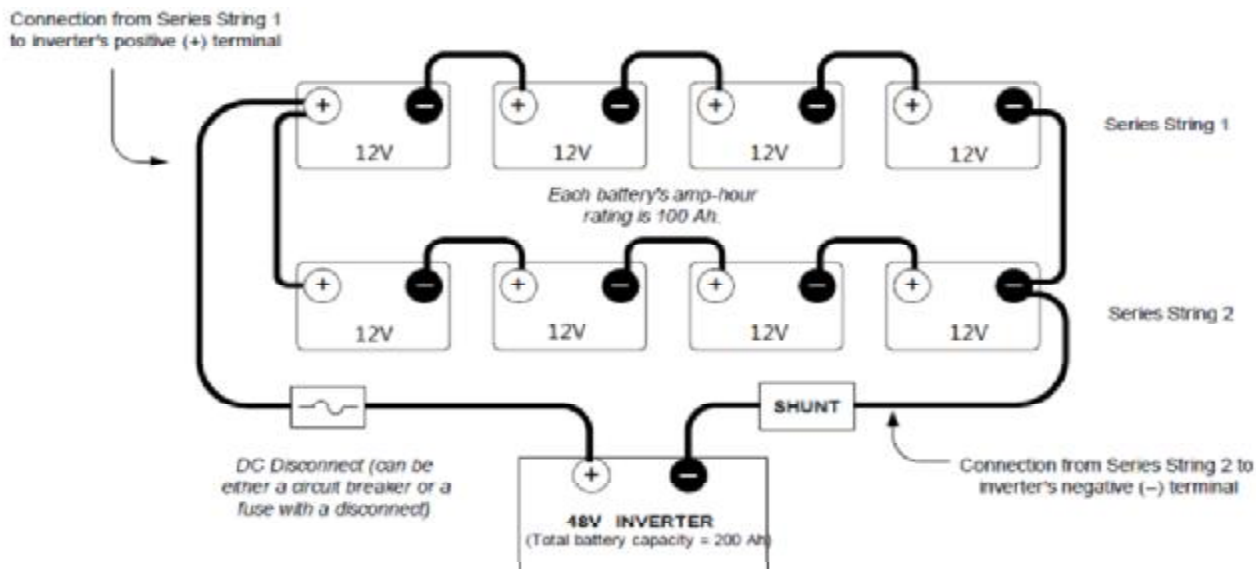

Table 4.2.3 Battery Wiring In Series-Parallel Configuration



Important: Connecting the positive and negative wires to the inverter from different strings ensures a balanced charge/discharge through the batteries, resulting in longer run times and improved battery life.

4.2.6 Batteries Maintenance

To get the best performance from an inverter system, the batteries must be properly setup and maintained. This includes setting the proper voltages for Bulk and Float charging. See the “**CAUTIONS**” in the section on Equalization Charging that follows. In addition, the battery terminals should be inspected, cleaned, and re-torqued if necessary.

Battery posts must be clean to reduce the resistance between the battery post and cable connection. A buildup of dirt or oxidation may eventually lead to the cable terminal overheating during periods of high current draw.

Use a stiff wire brush and remove all dirt and corrosion from the battery terminals and cables. Use an alkaline solution of baking soda and water to clean the terminals and neutralize any battery acid on the terminals or cable lugs.

Charge Rate

The maximum safe charge rate is related to the size and type of the batteries. Flooded lead acid batteries (with removable caps) can be charged at a high rate. Small batteries may require a lower charge rate. Check with your battery vendor for the proper battery charging rate for the batteries used in the system.

Bulk Voltage

This is the maximum voltage the batteries will be charged to during a normal charge cycle. Gel cell batteries are set to a lower value and non-sealed batteries are set to a higher voltage setting.

Float Voltage

The Float voltage is set lower than the Bulk voltage and provides a maintenance charge on the batteries to keep them in a ready state.

Temperature Compensation

For optimal battery charging, the Bulk and Float charge rates should be adjusted according to the temperature of the battery. This can be accomplished automatically by using a BTS. The sensor attaches directly to the side of one of the batteries in the bank and provides precise battery temperature information. When battery charging voltages are compensated based on temperature, the charge voltage will vary depending on the temperature around the batteries. The following table describes approximately how much the voltage may vary depending on the temperature of the batteries.

If you have liquid lead acid batteries (non-sealed), you may need to periodically equalize your batteries. Check the water level monthly to maintain it at the appropriate level.

Important: If the battery temperature is allowed to fall to extremely cold temperatures, the inverter with a BTS may not be able to properly recharge cold batteries due to maximum voltage limits of the inverter. Ensure the batteries are protected from extreme temperatures.

5 Troubleshooting Guide

Troubleshooting contains information about how to troubleshoot possible error conditions while using the X Series Inverter & Charger.

The following chart is designed to help you quickly pinpoint the most common inverter failures.

Indicator and Buzzer

Status	Item	Indicator On Front Panel								Indicator On Remote Module			Buzzer
		Utility Power On	Inverter On	Fast Charge	Float Charge	Alarm	Over-Temp Trip	Over-Load Trip	Power Save On	CHARGER ON	INVERTER ON	ALARM	
Line Mode	C.C	√	×	√	×	×	×	×	×	√	×	×	×
	C.V	√	×	√, Blink	×	×	×	×	×	√	×	×	×
	Float	√	×	×	√	×	×	×	×	√	×	×	×
	Standby	√	×	×	×	×	×	×	×	×	×	×	×
Inv Mode	Inverter On	×	√	×	×	×	×	×	×	×	√	×	×
	Power Saver	×	×	×	×	×	×	×	√	×	×	×	×
Inv Mode	Battery Low	×	√	×	×	√	×	×	×	×	√	√	Beep 0.5s every 5s
	Battery High	×	√	×	×	√	×	×	×	×	√	√	Beep 0.5s every 1s
	Overload On Inverter Mode	×	√	×	×	√	×	√	×	×	√	√	Refer to “Audible alarm”
	Over-Temp On Inverter Mode	×	√	×	×	√	√	×	×	×	√	√	Beep 0.5s every 1s
	Over-Temp On Line Mode	√	×	√	×	√	√	×	×	√	×	√	Beep 0.5s every 1s
	Over Charge	√	×	√	×	√	×	×	×	√	×	√	Beep 0.5s every 1s
Fault Mode	Fan Lock	×	×	×	×	×	×	×	×	×	×	×	Beep continuous
	Battery High	×	√	×	×	×	×	×	×	×	√	×	Beep continuous
	Inverter Mode Overload	×	×	×	×	×	×	√	×	×	×	×	Beep continuous
	Output Short	×	×	×	×	√	×	√	×	×	×	√	Beep continuous
	Over-Temp	×	×	×	×	×	√	×	×	×	×	×	Beep continuous
	Over Charge	×	×	√	×	×	×	×	×	√	×	×	Beep continuous
Fault Mode	Back Feed Short	×	×	×	×	×	×	×	×	×	×	×	Beep continuous

Symptom	Possible Cause	Recommended Solution
Inverter will not turn on during initial power up.	Batteries are not connected, loose battery-side connections.	Check the batteries and cable connections. Check DC fuse and breaker.
	Low battery voltage.	Charge the battery.
No AC output voltage and no indicator lights ON.	Inverter has been manually transitioned to OFF mode.	Press the switch to Power saver on or Power saver off position.
AC output voltage is low and the inverter turns loads OFF in a short time.	Low battery.	Check the condition of the batteries and recharge if possible.
Charger is inoperative and unit will not accept AC.	AC voltage has dropped out-of-tolerance	Check the AC voltage for proper voltage and frequency.
Charger is supplying a lower charge rate.	Charger controls are improperly set. Low AC input voltage. Loose battery or AC input connections.	Refer to the section on adjusting the "Charger Rate". Source qualified AC power.. Check all DC /AC connections.
Charger turns OFF while charging from a generator.	High AC input voltages from the generator.	Load the generator down with a heavy load. Turn the generator output voltage down.
Sensitive loads turn off temporarily when transferring between grid and inverting.	Inverter's Low voltage trip voltage may be too low to sustain certain loads.	Choose narrow AC voltage in the DIP switch, or Install a UPS if possible.
Noise from Transformer/case*	Applying specific loads such as hair drier	Remove the loads

***The reason for the noise from transformer and/or case**

When in inverter mode sometimes the transformer and/or case of the inverter may vibrate and make noise.

If the noise comes from transformer:

According to the characteristics of our inverter, mainly there is one type of load which most likely may cause rattles of transformer.

That is half wave load: A load that uses only half cycle of the power (see figure 1). This tends to cause an imbalance of the magnetic field of the transformer, reducing its rated working freq from 20KHz to maybe 15KHz (it varies according to different loads). In such a case the frequency of noise falls exactly into the range (200Hz-20KHz) that human ears can hear.

The most common load of such kind is a hair drier.

If the noise comes from the case:

Normally when loaded with inductive loads, the magnetic field generated by the transformer keeps attracting or releasing the steel case at a specific freq, this may also cause noise.

Reducing the load power or using an inverter with bigger capacity will normally solve this problem.

The noise will not do any harm to the inverter or the loads.

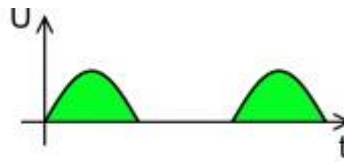

Figure 1 Half Cycle Load Waveform

6 Warranty

We offer a 1 year limited warranty.

The following cases are not covered under warranty.

1 DC polarity reverse.

The inverter is designed without DC polarity reverse protection. A polarity reverse may severely damage the inverter.

2 Wrong AC wiring

3 Operating in a wet environment.

4 Operating with an undersized generator or generator with unqualified wave form.

7 Ordering Information

Model Identification and Numbering Conventions

The X series Inverter is identified by the model/serial number labels. The Serial Number can be located on the mounting rail or inside the top cover. Model Number labels may be located on the bottom side of the front cover or possibly inside the front cover. All the necessary information is provided on the label such as AC output voltage, power and frequency (punch holes).

The inverter also has a letter designator followed by 4-6 digits (depending on revision). The model number describes the type of inverter, the output specifications, the required battery voltage and the output voltage and frequency.

Typical Part Number	HP Basic Series	20 Power Rating	12 Battery Voltage	E Output Voltage
1. Basic Series				
HP: Inverter & Charger				
HP-PV: Inverter & Charger & Solar Controller				
2. Power Rating				
10=1000W 15=1500W 20=2000W 30=3000W				
40=4000W 50=5000W 60=6000W 80=8000W				
100=10KW 120=12KW				
3. Battery Voltage				
12=12VDC 24=24VDC 48=48VDC				
4. Output Voltage				
No Letter=LV120VAC E=HV230VAC D=120/230VAC				

Figure 6-1 Product Identification

Appendix 1

Electrical Specifications											
	Model	1.0KW	1.5KW	2.0KW	3.0KW	4.0KW	5.0KW	6.0KW	8.0KW	10.0K W	12.0K W
Inverter Output	Continuous Output Power	1.0KW	1.5KW	2.0KW	3.0KW	4.0KW	5.0KW	6.0KW	8.0KW	10.0K W	12.0K W
	Surge Rating(20Secs)	3.0KW	4.5KW	6.0KW	9.0KW	12.0K W	15.0K W	18.0K W	24.0K W	30.0K W	36.0K W
	Output Waveform	Pure Sine wave/Same as input(Bypass Mode)									
	Nominal Efficiency	>88%(Peak)									
	Line Mode Efficiency	>95%									
	Power Factor	0.9-1.0									
	Nominal Output Voltage rms	100-110-120Vac/220-230-240Vac									
	Output Voltage Regulation	±10% RMS									
	Output Frequency	50Hz±0.3Hz/60Hz±0.3Hz									
	Short Circuit Protection	Yes(1sec after fault)									
	Typical transfer Time	10ms(Max)									
THD	<10%										
DC Input	Nominal Input Voltage	12.0Vdc/24.0Vdc/48.0Vdc					24.0Vdc/48.0Vdc		48.0Vdc		
	Minimum Start Voltage	10.0Vdc/10.5Vdc for 12Vdc Mode					*2 for 24Vdc, *4 for 48Vdc;				
	Low Battery Alarm	10.5Vdc/11.0Vdc for 12Vdc Mode									
	Low Battery Trip	10.0Vdc/10.5Vdc for 12Vdc Mode									
	High Voltage Alarm	16.0Vdc for 12Vdc Mode									
	Low Battery voltage recover	15.5Vdc for 12Vdc Mode									
	Idle Consumption-Search Mode	< 25 W when Power Saver On.(Refer to Table)									
Charger	Output Voltage	Depends on battery type (Refer to Table 2.5.2)									
	Charger Breaker Rating	20A	20A	20A	25A	32A	40A	40A	50A	80A	80A
	Max Charge Power Rate	1/3 Rating Power (Refer to Table 2.5.3)									
	Battery Initial Voltage for Start	10-15.7Vdc for 12Vdc Mode					*2 for 24Vdc, *4 for 48Vdc;				
	Over Charge Protection S.D.	15.7Vdc for 12Vdc Mode									
BTS	Battery Temperature Sensor (Optional)	Yes(Refer to the table) Variances in Charging Voltage & S.D Voltage Base on the Battery Temperature.									

Bypass & Protection	Input Voltage Waveform	Sine wave(Grid or Generator)										
	Nominal Voltage	100-110-120Vac/220-230-240Vac										
	Max Input AC Voltage	150VAC For 120Vac LV Mode ; 300VAC For 230Vac HV Mode;										
	Nominal Input Frequency	50Hz or 60Hz										
	Low Freq Trip	47±0.3Hz for 50Hz, 57±0.3Hz for 60Hz										
	High Freq Trip	55±0.3Hz for 50Hz, 65±0.3Hz for 60Hz										
	Overload protection(SMPS load)	Circuit Breaker										
	Output Short circuit protection	Circuit Breaker										
	Bypass breaker rating	20A	20A	20A	25A	32A	40A	40A	50A	80A	80A	
	Transfer switch rating	30Amp for UL & TUV				40Amp for UL			80Amp for UL			
	Bypass without battery connected	Yes (Optional)										
	Max bypass current	30Amp				40Amp			80Amp			
Solar Charger (Optional)	Rated Voltage	12Vdc/24Vdc/48Vdc										
	Solar Input Voltage Range	15-45Vdc/30-70Vdc/60-100Vdc										
	Rated Charge Current	40 or 60A										
	Rated Output Current	15A										
	Self Consumption	< 10mA										
	Bulk Charge(Default)	14.5Vdc for 12Vdc Mode				(*2 for 24Vdc, *4 for 48Vdc)						
	Floating Charge(Default)	13.5Vdc for 12Vdc Mode										
	Equalization Charge(Default)	14.0Vdc for 12Vdc Mode										
	Over Charge Disconnection	14.8Vdc for 12Vdc Mode										
	Over Charge Recovery	13.6Vdc for 12Vdc Mode										
	Over Discharge Disconnection	10.8Vdc for 12Vdc Mode										
	Over Discharge Reconnection	12.3Vdc for 12Vdc Mode										
Temperature Compensation	- 13.2mV/°C for 12Vdc Mode											
Ambient Temperature	0~40°C (Full load) 40~60°C (Derating)											
Mechanical Specifications	Mounting	Wall Mount										
	Inverter Dimensions(L*W*H)	388*415*200mm				488*415*200mm			588*415*200mm			
	Inverter Weight(Solar Chg)Kg	21+2.5	22+2.5	23+2.5	27+2.5	38+2.5	48+2.5	49+2.5	60+2.5	66+2.5	70+2.5	
	Shipping Dimensions(L*W*H)	550*520*310mm				650*520*310mm			750*520*310mm			

	Shipping Weight(Solar Chg)Kg	23+2.5	24+2.5	25+2.5	29+2.5	40+2.5	50+2.5	51+2.5	62+2.5	68+2.5	72+2.5
Display		Status LEDs/Status LEDs+LCD									
Standard Warranty		1 year									

Appendix 2 Battery Temperature Compensation (BTS)

Condition	INV/CHG Status	Transfer Point
Charger Mode	CHG On >>>CHG Off	BTS \geq 50°C
	CHG Off >>> CHG On	BTS \leq 40°C
Inverter Mode	S.D Point + 0.5Vdc	40°C \leq BTS \leq 50°C
	Over Temp Fault	BTS \geq 50°C

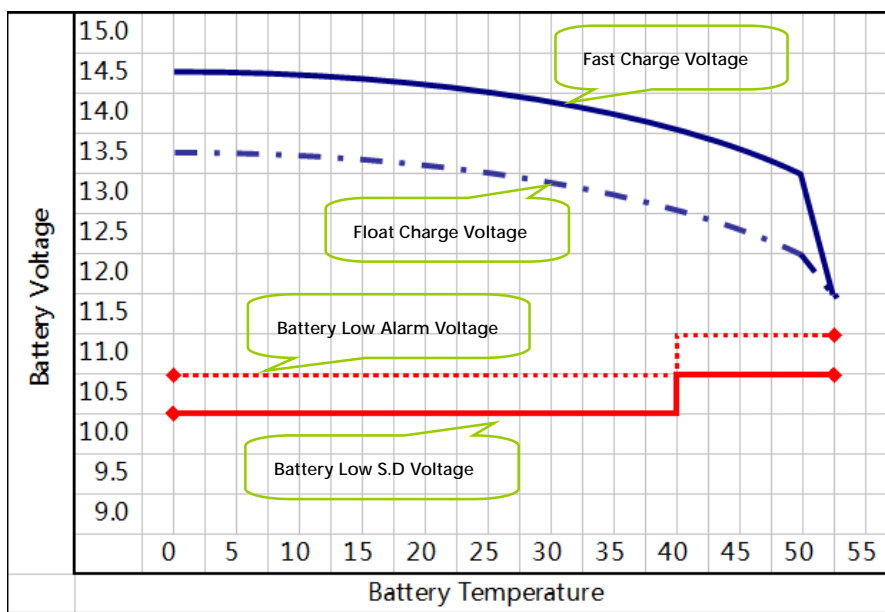

Default output voltage for Float and Absorption are at 25°C.

Reduce Float voltage follows Float voltage and Raised Absorption voltage follows Absorption voltage.

In a adjust mode temperature compensation does not apply.

Note: Specifications subject to change without notice.

Important: The battery charger control circuit operates from the battery voltage. If the battery voltage falls below 7 Volts, the inverter/charger will not operate. The battery must first be recharged using a stand-alone charger to bring the voltage up to a level where the inverter/charger can operate.